

# STARMATIC 63-000 BACK-UP ALARM

- IMPORTANT:** Please read all of the following instructions before installing your new Star Back-Up alarm. This instruction sheet applies only for installation of the Star model 63-000 **on negative ground vehicles only.**
- CAUTION:** All of our DC powered Back-Up Alarms are polarity sensitive. All wires connected to the positive terminal of the battery should be fused at the battery for their rated load. **Testing the alarm before this fuse is properly installed will void the warranty on the alarm.**
- The Starmatic Self-Adjusting Back-up Alarm must be installed in the rear of the vehicle in a location which will minimize the possibility of damage to the alarm due to collision or flying objects.
- The **SOUND OPENING MUST FACE TO THE REAR** with no obstructions that could reduce the surrounding sound level heard by the alarm. Since this alarm is designed to concentrate its sound output to the hazard zone only, it should be mounted approximately **4 FEET ABOVE GROUND LEVEL.**
- The Starmatic must "hear" the surrounding sound level in order to adjust its output amplitude. Mounting location can affect the Starmatic 63-000 automatic adjustment function. The installer should insure the Starmatic is installed in a location which will maximize its output level. After finding a good position for the alarm, fasten it in place with 5/16" nuts, bolts, and lock washers (not supplied).
- Connect the positive terminal on the alarm to the back-up lights or to an independent actuating switch as shown in the diagram on the reverse side of this sheet. **Please Note :** *The vehicles supply voltage must be the same as the voltage rating specified on this alarm. Any other voltage applied will void the warranty.*
- Connect the negative terminal on the alarm to the negative side of the battery or a good chassis ground.
- Use 14 AWG or 16 AWG wire for installation.
- CAUTION:** All Back-Up alarms should be **TESTED DAILY** before operation the vehicle. Alarms should be listed on the daily maintenance report, and a record of the daily test should be recorded in the vehicle maintenance file.

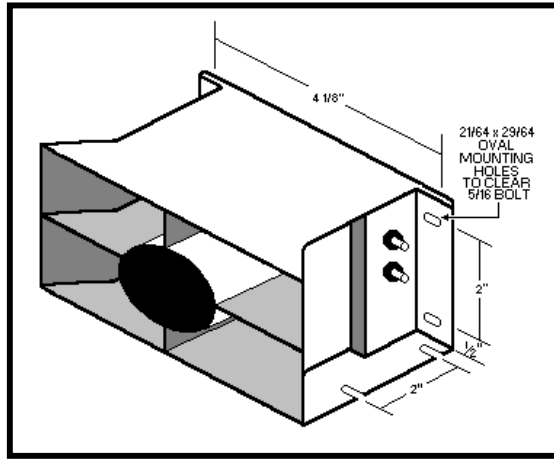

## Wiring Diagram

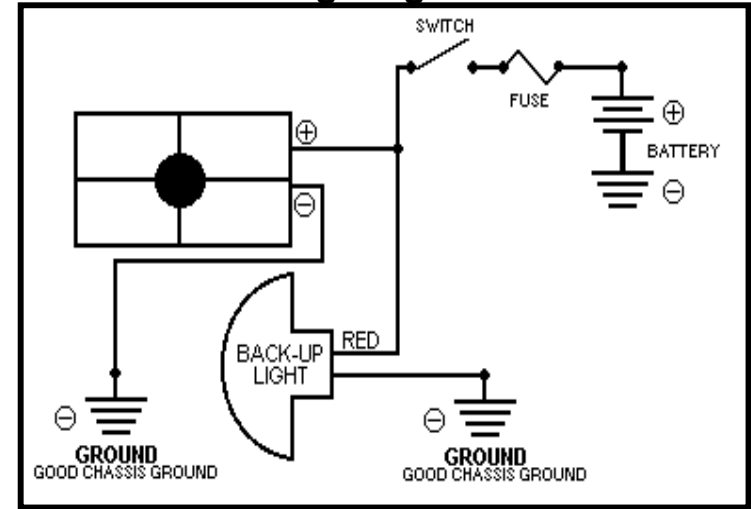

## ONE YEAR LIMITED WARRANTY

The manufacturer warrants each new product against factory defects in material and workmanship for one year after the date of purchase. The owner will be responsible for returning to the Service Center any defective item(s) with the transportation costs prepaid. The manufacturer will, without charge, repair or replace at its option, products which its inspection determines to be defective. Repair or replacement item(s) will be returned to the purchaser with transportation costs prepaid from the service point. A copy of the purchaser's receipt must be returned with the defective item(s) in order to qualify for the warranty coverage. Exclusions from this warranty are FLASH TUBES/BULB(S) as well as the finish. This warranty shall not apply to any product which has been altered, such that in the manufacturer's judgment the performance or reliability has been affected or damage has resulted from abnormal use or service.

There are no warranties expressed or implied (including any warranty of merchantability or fitness), which extend this warranty period. The loss of use of the product, loss of time, inconvenience, commercial loss or consequential damages, including costs of any labor, are not covered. The manufacturer reserves the right to change the design of the product without assuming any obligation to modify any product previously manufactured.

This warranty gives you specific legal rights. You might also have additional rights which may vary from state to state. Some states do not allow limitations on how long an implied warranty lasts. Some states do not allow the exclusion or limitation of incidental or consequential damages. Therefore, the above limitation(s) or exclusion(s) may not apply to you.

If you have any questions concerning this or any other Star product, please contact our **Customer Service Department** at (585) 226-9787.

If a product must be returned for any reason, please contact our Customer Service Department to obtain a Returned Goods Authorization number (RGA #) before you ship the product to Star. Please write the RGA # clearly on the package near the mailing label.

If you have any questions concerning this or any other Star product or need warranty service, please contact our Customer Service Department at (585) 226-9787.

**STAR**  
WARNING  
SYSTEMS

**Star Headlight & Lantern Co., Inc.**

455 Rochester Street  
Avon, NY 14414



Phone: 585-226-9500  
Fax: 888-478-2797

www.star1889.com

www.star1889.com

**Signal.**  
VEHICLE PRODUCTS

PLITSTR34 REV. D 6/1/06

**STAR**  
WARNING  
SYSTEMS

**Star Headlight & Lantern Co., Inc.**

455 Rochester Street  
Avon, NY 14414



Phone: 585-226-9500  
Fax: 888-478-2797

www.star1889.com

www.star1889.com

**Signal.**  
VEHICLE PRODUCTS