

64 SERIES BACK-UP ALARMS

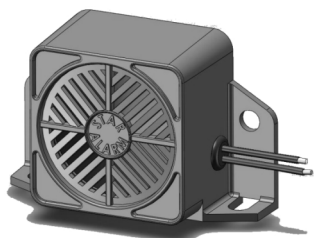

64 Series

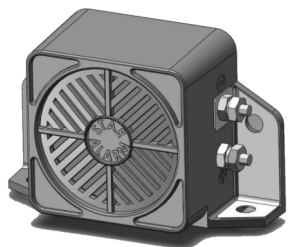

64G Series

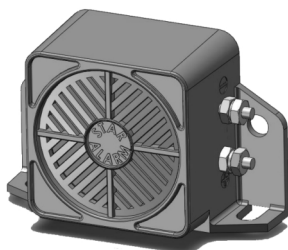

64L Series

	Model #	dB	Current	Voltage
Wires				
Single Tone	64-087	87	0.3A	12-36 vdc
	64-097	97	0.3A	12-36 vdc
	64-097-12	97	0.3A	12 vdc
	64-102	102	0.3A	12-36 vdc
	64-107-12	107	0.7A	12 vdc
	64-107-24	107	0.3A	24-36 vdc
Dual Tone	64-097DT	97	0.3A	12-36 vdc
	64-102DT	102	0.7A	12 vdc
Auto-Adjusting	64-707A	77-97	0.3A	12-24 vdc
	64-802A	82-102	0.3A	12-24 vdc
	64-807A	87-107	0.7A	12 vdc
Lugs / No Wires / Grounding Strap				
Single Tone	64G-087	87	0.3A	12-36 vdc
	64G-097	97	0.3A	12-36 vdc
	64G-097-12	97	0.3A	12 vdc
	64G-102	102	0.3A	12-36 vdc
	64G-107-12	107	0.7A	12 vdc
	64G-107-24	107	0.3A	24-36 vdc
Dual Tone	64G-097DT	97	0.3A	12-36 vdc
	64G-102DT	102	0.7A	12 vdc
Auto-Adjusting	64G-707A	77-97	0.3A	12-24 vdc
	64G-802A	82-102	0.3A	12-24 vdc
	64G-807A	87-107	0.7A	12 vdc
Lugs Only / No Wires / No Grounding Strap				
Single Tone	64L-097-12	97	0.3A	12 vdc

Dual Tone units emit an alternating high/low tone.
Auto-Adjusting units will automatically adjust the output volume based upon the ambient noise.



IMPORTANT: Please read all of the following instructions before installing your new Star back-up alarm. This instruction sheet applies only for installation of the models listed above **on negative ground vehicles only.**

CAUTION: All of our DC powered back-up alarms are polarity sensitive. All wires connected to the positive terminal of the battery should be fused at the battery for their rated load. **Testing the alarm before this fuse is properly installed will void the warranty on the alarm.**

1. Mount the alarm in the rear of the vehicle with the sound opening outward towards the hazard zone.
2. For the plain 64 Series, connect the black wire to the negative side of the battery or a good chassis ground. For the 64L Series, connect the top post (shown to the right) to the negative side of the battery or a good chassis ground. The 64G series has a self grounding strap on the right mounting flange. It can be grounded through the mounting bolt (not included) to the chassis of the vehicle.
3. For the plain 64 Series, connect the red wire to an independent actuating switch or splice it into the back-up lights as shown in the diagram below. For the 64L and 64G Series, connect the bottom post (shown above) to an independent actuating switch or splice it into the back-up lights. **Please Note:** The vehicles supply voltage must be the same as the voltage rating specified on the alarm you are installing. Any other voltage applied will void the warranty.

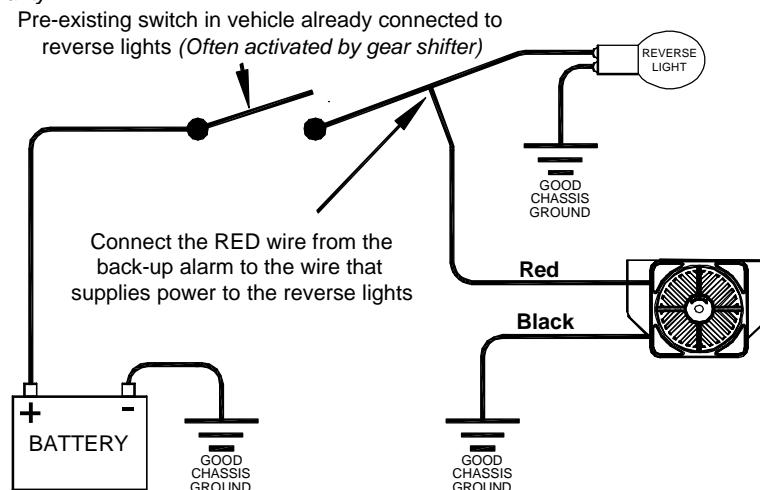
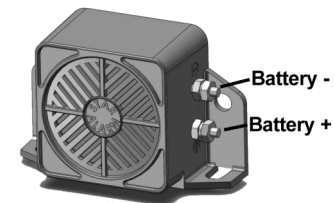

ONE YEAR LIMITED WARRANTY

The manufacturer warrants each new product, under normal use, against factory defects in material and workmanship for one year after the date of purchase. The owner will be responsible for returning to the Service Center any defective item(s) with the transportation costs prepaid. The manufacturer will, without charge, repair or replace at its option, products, or part(s), which its inspection determines to be defective. Repaired or replacement item(s) will be returned to the purchaser with transportation costs prepaid from the service point. A copy of the purchaser's receipt must be returned with the defective item(s) in order to qualify for the warranty coverage.

Exclusions from this warranty include, but are not limited to, bulbs, strobe tubes, domes, and/or the finish. This warranty shall not apply to any light, which has been altered, such that in the manufacturer's judgment, the performance or reliability has been affected, or if any damage has resulted from abnormal use or service. This warranty does not apply to defect or damage occurring as a result of disaster, accident, abuse, misuse, lightning, power surges, or failure to follow instructions in any enclosed manuals. Any damage or defects occurring as a result of any unauthorized service or repairs by unauthorized persons shall be excluded from this warranty.

There are no warranties expressed or implied (including any warranty of merchantability or fitness), which extend this warranty period. **The loss of use of the product, loss of time, inconvenience, commercial loss or consequential damages, including costs of any labor, are not covered.** The manufacturer reserves the right to change the design of the product without assuming any obligation to modify any product previously manufactured.

This warranty gives you specific legal rights. You might also have additional rights which may vary from state to state. Some states do not allow limitations on how long an implied warranty lasts. Some states do not allow the exclusion or limitation of incidental or consequential damages. Therefore, the above limitation(s) or exclusion(s) may not apply to you.

Star Headlight & Lantern Co., Inc.

455 Rochester Street Avon, NY 14414 Phone: 585-226-9787 FAX: 888-478-2797



www.starheadlight.com

PL1T421 REV. C 12/1/10

Star Headlight & Lantern Co., Inc.

455 Rochester Street Avon, NY 14414 Phone: 585-226-9787 FAX: 888-478-2797



www.starheadlight.com