



PROUDLY MADE IN THE USA  
An ISO 9001 Certified Company



**Strobe**  
WARNING LIGHTS

# REMOTE STROBE PACKS

Models RP242 and RP244

Owner's Manual & Installation Instructions

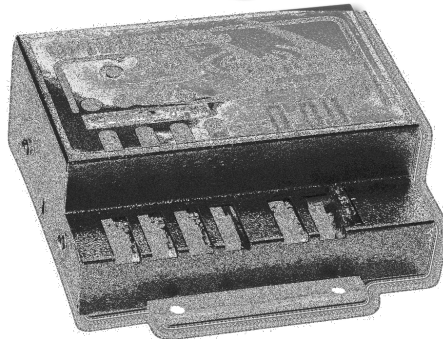

<u>Model</u>	<u># of Heads</u>	<u>Total Watts</u>	<u>Joules per Side</u>	<u>Amps</u>
RP242	2	40W	17.0J	4.2A
RP244	4	75W	31.9J	7.8A



**Star Headlight & Lantern Co., Inc.**

455 Rochester Street  
Avon, NY 14414



Phone: 585-226-9500  
Toll Free Fax: 888-478-2797

[www.star1889.com](http://www.star1889.com)





# Table of Contents

<b>SAFETY WARNINGS</b> .....	<b>1</b>
<b>MOUNTING</b> .....	<b>2</b>
<b>ELECTRICAL CONNECTIONS</b> .....	<b>3-6</b>
Wiring Diagrams.....	5-6
<b>CONNECTING REMOTE HEADS</b> .....	<b>7</b>
<b>TROUBLESHOOTING</b> .....	<b>8-9</b>
<b>SERVICE &amp; WARRANTY</b> .....	<b>10</b>



## **WARNING!**

This light utilizes high-intensity strobe lights. **DO NOT** stare directly into the light while it is on, as momentary blindness and/or permanent eye damage may occur.

- ▶ **IMPORTANT:** Please read all of the following instructions before installing your new strobe system. This instruction sheet applies only to the models listed.
- ▶ **CAUTION:** All of our remote power supplies are polarity sensitive. They are polarity protected *only if the appropriate fuse* is used. All wires connected to the positive terminal of the battery should be fused at the battery for their rated load. **Testing the system before this fuse is properly installed will void the warranty on the light.**
- ▶ **Opening or tampering with your remote power supply will void the warranty.** The remote power supply must be mounted against a smooth metal surface in a dry location. **Water damage to the power supply will also void the warranty.** Typical mounting locations of your power supply include the interior firewall, beneath the seat of a truck, or inside a large toolbox.

## **NOTICE**

Due to continuous product improvements, we must reserve the right to change any specifications and information, contained in this manual at any time without notice. Star Headlight & Lantern Co., Inc. makes no warranty of any kind with regard to this manual, including, but not limited to, the implied warranties of merchantability and fitness for a particular purpose. Star Headlight & Lantern Co., Inc. shall not be liable for errors contained herein or for incidental or consequential damages in connection with the furnishing, performance, or use of this manual.

## Mounting The Pack

Mount the pack on a smooth metal surface to allow for adequate heat dissipation. Do not mount the pack near any external heat source, as this will retard its ability to dissipate heat sufficiently. Mount the Pack using four bolts (*not included*). When mounting, make sure a good electrical connection exists between the mounting plate and the vehicle chassis. This will help to eliminate any RF interference.



*When mounting the power pack and accessories, please be sure to keep any radio frequency sensitive equipment at least 20" from the power pack, cables, and/or wires which make up your strobe system. The pack has been designed to limit RFI emissions, but certain very sensitive equipment may still be affected. Symptoms may include, but are not limited to, sporadic operation and degraded performance. Star Headlight & Lantern Co., Inc. cannot assume any responsibility for any radio frequency induced malfunction or damage to any radios, sirens, lightbars, or any other equipment mounted within 20" of this strobe system. Any antennae mounted in the proximity of the system may cause your radio to suffer the aforementioned results.*

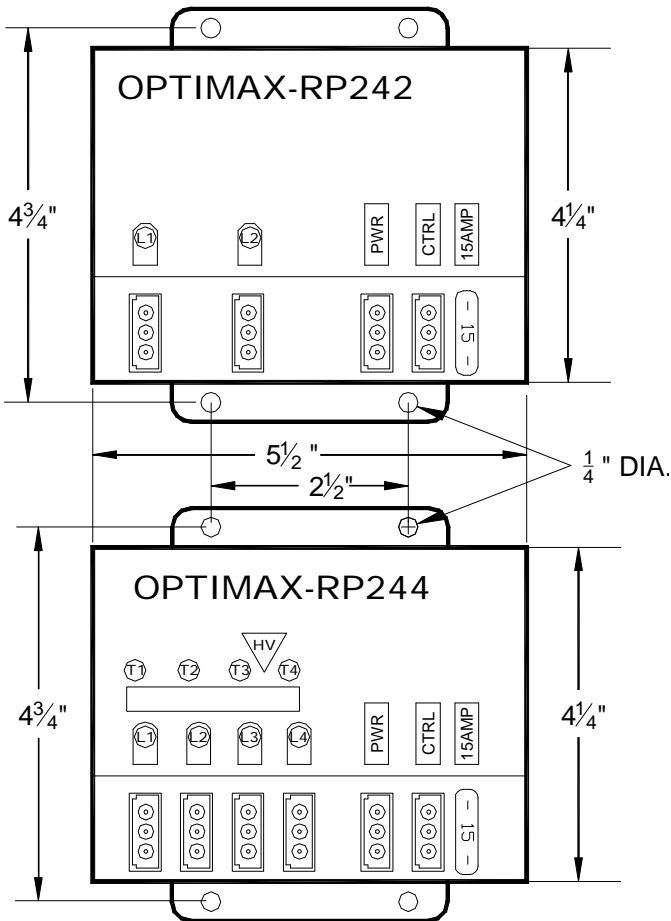

## Electrical Connections

There are a number of different configurations you may choose from when installing the RP242 and RP244 strobe packs:

- All Heads On and Off Together (*High Power Only*)
  - All Heads On and Off Together (*Low Power Only*)
  - All Heads On and Off Together (*High/Low switching Option*)
  - Separate Front and Rear Activation (*High Power Only*) †
  - Separate Front and Rear Activation (*Low Power Only*) †
  - Separate Front and Rear Activation (*High/Low Switching Option*) †
- † - RP244 Only

Decide which configuration will work best for you and proceed to the appropriate section, referring to the proper wiring diagram on page 5 or 6.

### All Heads On and Off Together (High Power Only)

(This setup is typically used for most "On/Off" applications)

1. The **black** and **white** wires from your PWR plug wire should be connected to a good chassis ground.
2. The **red** wire from your PWR plug and the **black** and **white** wires from the CTRL plug should be connected to +12VDC through your On/Off switch.

### All Heads On and Off Together (Low Power Only)

1. The **black** wire from your PWR plug on the pack should be connected to a good chassis ground.
2. The **red** and **white** wires from your PWR plug and the **black** and **white** wires from the CTRL plug should be connected to +12VDC through your On/Off switch.

### All Heads On and Off Together (With High/Low Power Switching Option)

1. The **black** wire from your PWR plug on the pack should be connected to a good chassis ground.
2. The **red** and **white** wires from your PWR plug and the **black** and **white** wires from the CTRL plug should be connected to +12VDC through the On/Off switch of the SP3860-2H-OP (*not included*).
3. The **white** wire from the PWR plug allows utilization of the High/Low (Day/Night Mode) option. The **white** wire from your PWR plug should be connected to the High/Low switch on the SP3860-2H-OP (*not included*). When the white wire is connected to power through your second switch the pack will operate under low power (Night Mode). When the second switch is in the "off" position, your pack will run under high power (Day Mode).

**CAUTION:** If you are using your own switch panel with the High/Low option, only apply power (+12VDC) to the **white** wire when the pack is on. Applying constant voltage to the white wire on the PWR connector while the pack is switched off may result in damage to the circuitry of the pack and will void the warranty. The SP3860-2H-OP (*not included*) is designed to comply with this requirement.

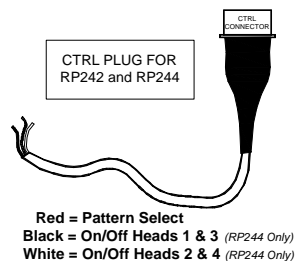
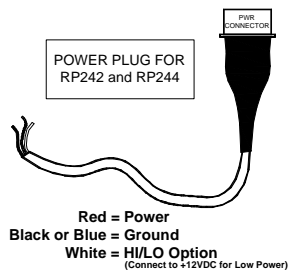
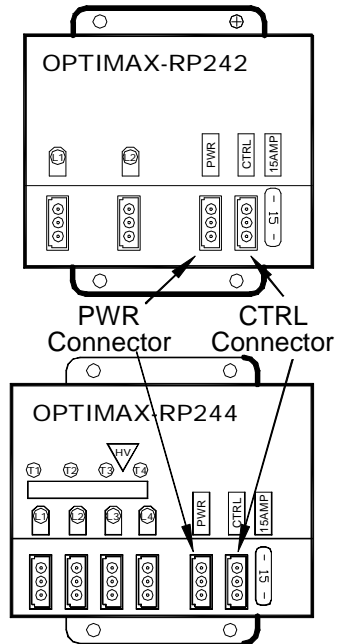

## **(Electrical Connections CONT'D)**

The RP244 is a four-outlet pack with the capability of switching two of the outlets separate from the other two (ex. Front vs. Rear). If you have an RP244 and would like your strobe pack wired this way, follow the appropriate instructions below, referring to the wiring diagram on page 6.

### **Separate Front and Rear Activation (High Power Only)**

1. The **black** and **white** wires from your PWR plug should be connected to a good chassis ground.
2. The **red** wire from your PWR plug should be connected directly to +12VDC.

**Please Note:** When the red wire is connected to +12VDC the pack will draw a small current (50 mA). If your vehicle will be sitting for extended periods of time (i.e. more than a few days), it is recommended this wire be routed through a switch.

3. Connect the **white** wire from the CTRL plug to one On/Off switch and the **black** wire from the CTRL plug to another On/Off switch.

### **Separate Front and Rear Activation (Low Power Only)**

1. The **black** wire from your PWR plug should be connected to a good chassis ground.
2. The **red** and **white** wires from your PWR plug should be connected directly to +12VDC.

**Please Note:** When the red wire is connected to +12VDC the pack will draw a small current (50 mA). If your vehicle will be sitting for extended periods of time (i.e. more than a few days), it is recommended the red and white PWR wires be routed through a switch.

3. Connect the **white** wire from the CTRL plug to one On/Off switch and the **black** wire from the CTRL plug to another On/Off switch.

### **Separate Front and Rear Activation (With High/Low Power Switching Option)**

1. The **black** wire from your PWR plug should be connected to a good chassis ground.
2. The **red** wire from your PWR plug should be connected directly to +12VDC.

**Please Note:** When the red wire is connected to +12VDC the pack will draw a small current (50 mA). If your vehicle will be sitting for extended periods of time (i.e. more than a few days), it is recommended the red wire be routed through a switch.

**CAUTION:** If you are using a switch on the red PWR plug wire, only apply power (+12VDC) to the **white** wire when the pack is on (power to the **red** PWR wire). Applying constant voltage to the **white** wire on the PWR connector while the pack is switched off may result in damage to the circuitry of the pack and will void the warranty.

3. Connect the **white** wire from the CTRL plug to one On/Off switch and the **black** wire from the CTRL plug to another On/Off switch.
4. The **white** wire from the PWR plug allows utilization of the High/Low (Day/Night Mode) option. The **white** wire from your power plug should be connected to a third switch on your switch panel (*not included*). When the white PWR wire is connected to power (+12VDC) through your third switch the pack will operate under low power (Night Mode). When the third switch is in the "off" position, your pack will run under high power (Day Mode).

### **RP242/RP244 Pattern Selection**

The **red** wire from the CTRL connector allows you to select the flash pattern you wish to have your strobe pack display. The pack is defaulted for Five-Flash mode. You can scroll through Pseudo-Random, Singleflash, Doubleflash, Tripleflash, Quadflash, and back to Five-Flash by turning your strobe lights on and briefly touching the **red** CTRL wire to +12VDC and releasing it. Continue to briefly touch and release this wire to +12VDC until you find the pattern desired. Once you have the pattern you like, tape the end of the **red** wire from the CTRL connector so that it does not come into contact with +12VDC.

# RP242/RP244 On/Off with High/Low Power Switching

(\* All heads activate together)

SP3860-2H-OP SWITCH PANEL (REAR VIEW)  
(for use with the RP242 or RP244 Strobe Paks)

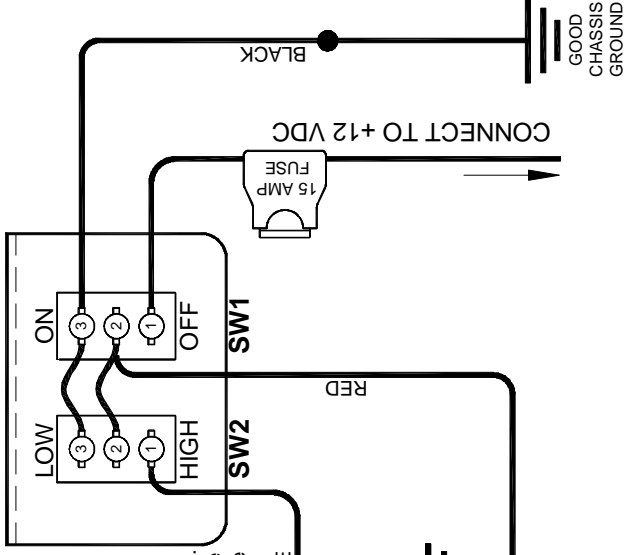

WHITE High/Low Wire:

**High Power Only:** Eliminate SW2, connect white wire with black to ground.

**Low Power Only:** Eliminate SW2 and connect white and red wires from the Power Connector with the black and white wires from the CTRL connector to SW1.

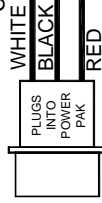

POWER CONNECTOR

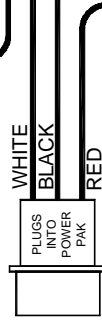

CTRL CONNECTOR

Pattern Select:

Touch and release to +12VDC to set pattern then tape off



## Connecting the Remote Heads:

1. Cable is required to connect the power pack to your remote strobe heads. Cable can be purchased from Star:

Length (ft)	Shielded Cable w/Amp Connector	SO Cable w/Weatherproof Connector
15	4415	3814-180"
20	4420	3814-240"
25	4425	3814-300"
30	4430	3814-360"
35	N/A	3814-420"

Length (ft)	Shielded Cable w/Amp Connector	SO Cable w/Weatherproof Connector
40	N/A	3814-480"
45	N/A	3814-540"
50	N/A	3814-600"
55	N/A	3814-660"
60	N/A	3814-720"

2. If you intend to use your own cable for connecting the remote heads, it must meet the following specifications: It must be three-conductor with 600V insulation, it must be a minimum 18 AWG for 0-30 ft. or 16 AWG for 31-60 ft., and it should be UV stabilized. Star does not recommend the use of any cable length greater than 60 feet, as the resistance may cause a drop in voltage resulting in inconsistent or complete loss of firing in the heads. Please use the Table below for proper cable sizes.

### Remote Power Pack Cabling Requirements

		0-20 ft.	21-30 ft.	31-50 ft	51-60 ft
Input Power and Ground Wires	RP242:	16 AWG	16 AWG	14 AWG	14 AWG
	RP244:	16 AWG	14 AWG	12 AWG	10 AWG
Wires to Remote Heads		18 AWG	18 AWG	16 AWG	16 AWG

3. If you are using your own cable and need connectors to attach the cable to the power pack, order part **#CK473**. The #CK473 consists of one connector (30041-20) and three male terminals (30042-16). This is also the replacement connector for any remote heads with the white AMP connectors (*NOT weatherproof*).
4. The AMP connector, found on the cables, which mates to the CK473 is a kit **#CK472**. The **#CK472** consists of one connector (448) and three female terminals (30042-15).
5. If you need a weatherproof connector kit *for your cable* to attach to our remote strobe heads, please order part **#CK702**. This kit contains one connector (30185-3), three female terminals (30042-30), and three rubber seals (30186-2).
6. If you need to order a weatherproof connector kit *for your strobe head* to mate with the connector on your cable (#CK702), please order part **#CK703**. This kit contains one connector (30185-4), three male pins (30042-29), and three rubber seals (30186-2).
7. For good, reliable connections between the cable system and the strobe heads in various weather and contamination conditions, it is strongly recommended that dielectric grease be used on the connectors. It should be applied to the rear of the connectors, where the wires enter, as well as into each terminal area where the connectors mate, before joining the two connectors together. We have found this procedure to be effective even under the most extreme of conditions. **Do Not Seal The Connectors Using Silicon Or RTV.**

### Automatic Power Up Head Check

Your new power pack comes with a safety feature which checks for proper operation of each individual strobe head each time you turn on the strobe pack. This feature works by quickly flashing each head once separately and determining if any of the heads did not flash. If two heads normally flash together and one should fail and does not flash during the start up test, the strobe pack will automatically reduce the output power to that particular side so that the "other" remaining head(s) isn't over powered. The power to that side will be cut in half until the strobe pack is turned off and on again.

The strobe pack will check all of the heads each time the pack is turned on EVEN if the head select feature is being used and only two heads are to be activated. After checking all of the heads, the pack will begin flashing normally. It takes approximately 0.250 sec. to check all of the heads.

**Note:** *If you replace the non-working head, it is necessary to cycle power to the pack before that head and the one that flashes with it will start flashing again at full power.*



**CAUTION:** High voltages exist in electronic strobe lights. Before attempting service on any strobe light, be sure to disconnect the power for at least five minutes to allow the capacitor to discharge. Failure to heed this warning may result in severe electrical shock and/or injury.

**Please Note:** Most strobe and rotating beacon failures can be traced to wiring and battery problems. Before attempting any service on the circuit itself, please be sure to check all connections and wiring to ensure the correct voltage and/or polarity is reaching your light or remote head.

## **TROUBLESHOOTING GUIDE**

*If a problem exists in only one head, a strobe tube may have burned out, or there may be an open electrical connection in the wiring harness or strobe head. Check connections at and between the strobe pack and the strobe head, including all wiring. Replace the malfunctioning heads and/or wiring harnesses if necessary.*

If none of your heads are flashing, follow these steps to determine the problem:

1. **Check all fuses**, including those at the battery, at the switch panel, in the dash, and on the pack (if applicable). The RP242 and RP244 have automotive “blade” type fuses. Remove these fuses, and check them to confirm they have not blown. Replace any blown fuses with only fuses of identical values. Replacing the fuse with the wrong rating may damage your pack and/or vehicle, and will void your warranty.
2. **Check the power and ground wires to your pack.** With the vehicle turned off and while the pack is running, measure the voltage across the red wire (pin 1) and the black wire (pin 2) of the **PWR** connector on the power pack. Push the probes of the test meter down into the connector at the wire entry points to contact the terminals for the measurement. A nominal 12.5 volts should be present. Low voltage to the pack can cause erratic flashing or even complete failure of the heads. A minimum of 9.5 volts should be present for the pack to operate properly.  
If you do not have proper voltage present your power or ground is bad. Skip to the section on **Checking a Bad Power or Ground Connection.**  
If your pack is receiving sufficient voltage then continue to step 3.
3. **Check the red wire on the CTRL connector to be sure that +12VDC is not applied to it.** The red CTRL wire is used for pattern select. Touching **AND RELEASING** this wire to +12VDC changes the flash patterns. A constant voltage applied to the red wire on the CTRL connector will prevent the strobe pack from flashing.
4. **Check that the proper voltage is reaching the necessary CTRL inputs.** The black and white wires on the CTRL plug should have +12VDC. With the vehicle turned off and while the pack is running, measure the voltage on the black and white wires of the CTRL connector. Push the probes of the test meter down into the connector at the wire entry points to contact the terminals for the measurement. A nominal 12.5 volts should be present. A minimum of 9.5 volts should be present for the pack to operate properly.

5. **Check each head.** If the leads in one of the heads have shorted out, the output voltage of the other heads may be held down as well. To test for this, unplug all of the heads and plug them in individually (one at a time). If your problem is a result of a shorted head, then each good head should function properly when connected by itself. Note: A burned out strobe tube does not cause a short and will not affect the operation of the remaining heads. If the problem is not with a shorted head and if proper voltage is reaching the pack, the problem is most likely internal to the pack. Call Star to obtain an R.G.A. number to return the pack for service.

### **Checking a Bad Power or Ground Connection**

If sufficient voltage is not reaching the pack perform the following tests:

1. **Test the Power at the Battery:** With the vehicle turned off and while the pack is running, measure the battery voltage at the battery. A nominal 12.5 volts should exist. If this voltage is below 9.5 volts the pack will not function properly and the problem is with the battery. This reading should not be more than 1-1.25 volts higher than the reading at the strobe pack itself.
2. **Test the Power Wire Between the Battery and the Switch:** Move to the ON/OFF switch in the cab and gain access to the rear of the switch panel. With the vehicle not running and the pack on at the high power setting, measure the voltage drop in the red wire by taking a reading with one probe on the positive side of the battery and the other probe in pin 1 of your switch. If this reading exceeds 0.25 volts then there is a poor connection between the switch and the battery in the red wire and it should be checked. **NOTE:** *Excessive voltage drop may be occurring in the connections on the switch panel. If you have one of our switches you can increase the contact pressure by removing the FASTON terminal from the tab on the switch. Using long nose pliers, gently squeeze the FASTON terminal together in the area that slides on to the tab of the switch. This will increase the pressure applied between the tabs and the connector and reduce voltage drop.*
3. **Test the Power Wire Between the Strobe Pack and the Switch:** This same procedure can be used to check the wires between the switch panel and the pack. Place one probe on the terminal at the switch and the other probe into the terminal with the corresponding wire color in the **PWR** connector on the pack. Once again if any of the readings exceed 0.25 volts then you should check those wires and their connections.
4. **Test your Ground Wire:** If you still have not located the problem, troubleshoot the connections between the good chassis ground and pin 2 (**black wire**) of the **PWR** connector on the power pack. With the vehicle not running and the pack on at the high power setting, measure the voltage drop in the Black (Ground) wire by taking a reading with one probe on the negative side of the battery and the other probe in pin 2 of your **PWR** connector. If this reading exceeds 0.25 volts then you have a bad ground.



## ONE YEAR LIMITED WARRANTY

*The manufacturer warrants each new product, under normal use, against factory defects in material and workmanship for one year after the date of purchase. The owner will be responsible for returning to the Service Center any defective item(s) with the transportation costs prepaid. The manufacturer will, without charge, **repair or replace at its option**, products, or part(s), which its inspection determines to be defective. Repaired or replacement item(s) will be returned to the purchaser with transportation costs prepaid from the service point. A copy of the purchaser's receipt must be returned with the defective item(s) in order to qualify for the warranty coverage.*

*Exclusions from this warranty include, but are not limited to, bulbs, strobe tubes, domes, and/or the finish. This warranty shall not apply to any light, which has been altered, such that in the manufacturer's judgment, the performance or reliability has been affected, or if any damage has resulted from abnormal use or service. This warranty does not apply to defect or damage occurring as a result of disaster, accident, abuse, misuse, lightning, power surges, or failure to follow instructions in any enclosed manuals. Any damage or defects occurring as a result of any unauthorized service or repairs by unauthorized persons shall be excluded from this warranty.*

There are no warranties expressed or implied (including any warranty of merchantability or fitness), which extend this warranty period. **The loss of use of the product, loss of time, inconvenience, commercial loss or consequential damages, including costs of any labor, are not covered.** The manufacturer reserves the right to change the design of the product without assuming any obligation to modify any product previously manufactured.

*This warranty gives you specific legal rights. You might also have additional rights that may vary from state to state. Some states do not allow limitations on how long an implied warranty lasts. Some states do not allow the exclusion or limitation of incidental or consequential damages. Therefore, the above limitation(s) or exclusion(s) may not apply to you.*

If you have any questions concerning this or any other product, please contact our **Customer Service Department** at (585) 226-9787.

If a product must be returned for any reason, please contact our Customer Service Department to obtain a Returned Goods Authorization number (RGA #) before you ship the product to Star. Please write the RGA # clearly on the package near the mailing label.



**Star Headlight & Lantern Co., Inc.**

455 Rochester Street  
Avon, NY 14414



Phone: 585-226-9500  
Toll Free Fax: 888-478-2797

[www.star1889.com](http://www.star1889.com)



# REMOTE STROBE HEAD INSTALLATION

- IMPORTANT:** Please read all of the following instructions before installing your new remote strobe system.
- The remote strobe head *must* be connected to a power pak to operate. You may use our two-outlet, four-outlet, or six-outlet paks. These heads may *or may not work* with alternate brand power paks. The installer accept any and all liability if this head is used in conjunction with any unapproved power paks.
- Connect your heads to your power pak using the proper cable: part #3820 for light duty cable, #3814 for heavy duty cable, or 4415 for shielded cable (used with the Optimax paks).
- If you intend to use your own cable, it must meet certain specifications as follows: It must be three-conductor with 600V insulation, minimum 18 AWG for 0-20 ft., 16 AWG for 21-30 ft. or 14 AWG for 31-50 ft. We do not recommend the use of any cable length greater than 50 feet, as the resistance might cause a drop in voltage resulting in inconsistent or complete loss of firing in the heads.
- For good, reliable connections between the cable system and the strobe tube head in various weather and contamination conditions, it is strongly recommended that a dielectric grease or more specifically **Truck-Lite NYK Corrosion Preventative Compound** (2 fl. oz. tubes) be used on the connectors. This compound is available from Truck-Lite. It should be applied and into each terminal area where the connectors mate, before joining the two connectors together. We have found this procedure to be effective even under the most extreme of conditions. **Do Not Seal The Connectors Using Silicon Or RTV.**
- A template is provided on the back of this sheet if you are installing model #SH3920 oval heads and need to drill a hole.
- If you must remove the weatherproof connector for any reason, please re-insert the wires back into their proper location. Please refer to the diagram below. If you need to order another weatherproof connector kit, please use part #CK703. This kit contains one connector (30185-4), three male pins (30042-29), and three rubber seals (30186-2).

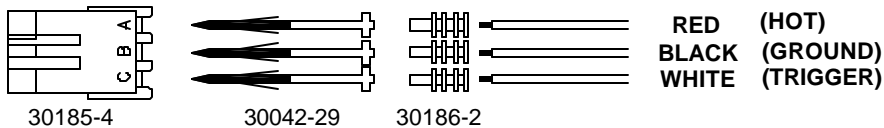

- If you need to order a weatherproof connector kit to mate with the CK703 (the connector on your strobe head), please use part #CK702 (not shown). This kit contains one connector (30185-3), three female pins (30042-30), and three rubber seals (30186-2).

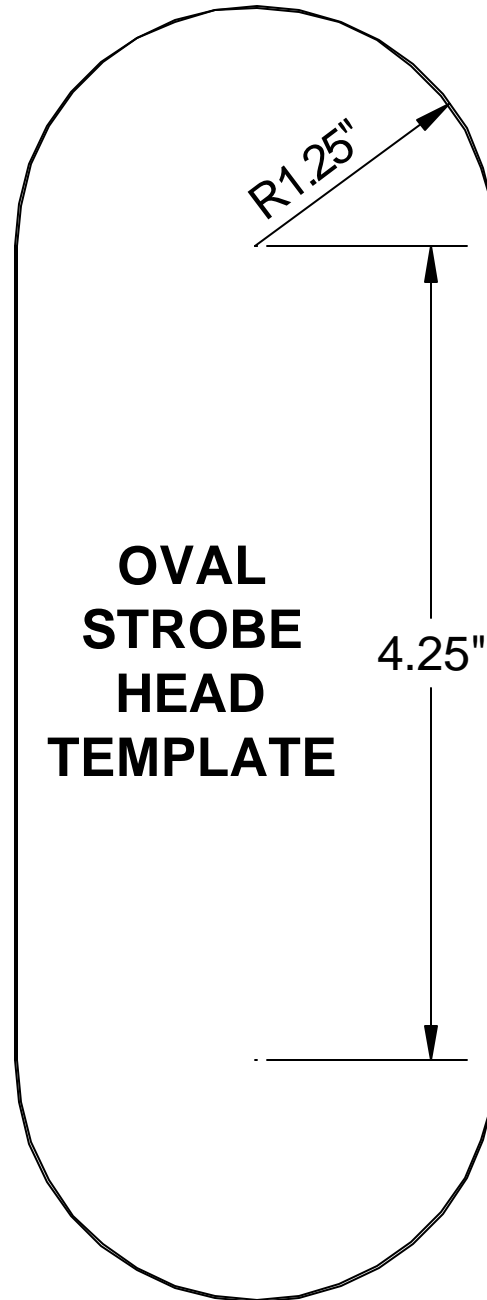

# ONE YEAR LIMITED WARRANTY

The manufacturer warrants each new product, under normal use, against factory defects in material and workmanship for one year after the date of purchase. The owner will be responsible for returning to the Service Center any defective item(s) with the transportation costs prepaid. The manufacturer will, without charge, **repair or replace at its option**, products, or part(s), which its inspection determines to be defective. Repaired or replacement item(s) will be returned to the purchaser with transportation costs prepaid from the service point. A copy of the purchaser's receipt must be returned with the defective item(s) in order to qualify for the warranty coverage.

Exclusions from this warranty include, but are not limited to, bulbs, strobe tubes, domes, and/or the finish. This warranty shall not apply to any light, which has been altered, such that in the manufacturer's judgment, the performance or reliability has been affected, or if any damage has resulted from abnormal use or service. This warranty does not apply to defect or damage occurring as a result of disaster, accident, abuse, misuse, lightning, power surges, or failure to follow instructions in any enclosed manuals. Any damage or defects occurring as a result of any unauthorized service or repairs by unauthorized persons shall be excluded from this warranty.

There are no warranties expressed or implied (including any warranty of merchantability or fitness), which extend this warranty period. **The loss of use of the product, loss of time, inconvenience, commercial loss or consequential damages, including costs of any labor, are not covered.** The manufacturer reserves the right to change the design of the product without assuming any obligation to modify any product previously manufactured.

This warranty gives you specific legal rights. You might also have additional rights which may vary from state to state. Some states do not allow limitations on how long an implied warranty lasts. Some states do not allow the exclusion or limitation of incidental or consequential damages. Therefore, the above limitation(s) or exclusion(s) may not apply to you.

If you have any questions concerning this or any other product, please contact our **Customer Service Department** at (716) 226-9787. If a product must be returned for any reason, please contact our Customer Service Department to obtain a Returned Goods Authorization number (RGA #) before you ship the product back. Please write the RGA # clearly on the package near the mailing label.



**CAUTION:** High voltages exist in electronic strobe lights. Before attempting service on any strobe light, be sure to disconnect the power for at least five minutes to allow the capacitor to discharge. Failure to heed this warning may result in severe electrical shock and/or injury.

**Please Note:** Most strobe and rotating beacon failures can be traced to wiring and battery problems. Before attempting any service on the circuit itself, please be sure to check all connections and wiring to ensure the correct voltage and/or polarity is reaching your light or remote head.



**Star Headlight & Lantern Co., Inc.**

455 Rochester Street  
Avon, NY 14414  
Phone: 585-226-9500  
Toll Free Fax: 888-478-2797



www.star1889.com



REV. H 4/5/04 PLITSTR87

# Model SH3940

## Remote Strobe Head

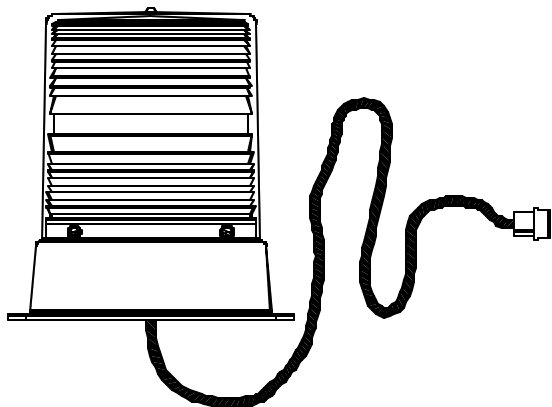

**IMPORTANT:** Please read all of the following instructions before installing your new warning light. This instruction sheet applies only to the model listed at the top of this sheet.



**CAUTION:** High voltages exist in electronic strobe lights. Before attempting service on any strobe light, be sure to disconnect the power for at least five minutes to allow the capacitor to discharge. Failure to heed this warning may result in severe electrical shock and/or injury.

**Please Note:** Most strobe and rotating beacon failures can be traced to wiring and battery problems. Before attempting any service on the circuit itself, please be sure to check all connections and wiring to ensure the correct voltage and/or polarity is reaching your light or remote head.

**Please Note:** *The Model SH3940 is a remote strobe head and MUST be connected to a remote strobe power supply. It is not designed to flash when connected DIRECTLY to +12 VDC.*

1. Your new warning light comes complete with a foam mounting gasket, two mounting screws, two lock washers, and two rubber well nuts.
2. Remove the foam gasket from the shipping box. Each gasket comes furnished with three holes, two outer and a center hole. (NOTE: You may have to stretch the gasket to find the location of the three holes.) Place the gasket in the exact position the light is to be mounted.
3. Using the gasket as a template, mark three holes on the mounting surface. Take care to ensure that the gasket does not move while you are marking each of the three holes.

4. Remove the gasket and drill a 3/8" hole in the **two outer locations only**. Drill a 1" hole in the center location for the cable, taking care to remove any burrs and file any sharp edges that may damage the cable.

**CAUTION:** Take care not to drill through the headliner of the vehicle below.

5. Push the enclosed rubber well nuts through the two outer holes in the vehicle, until the bottom side of the wider lip rests on the surface of the vehicle.

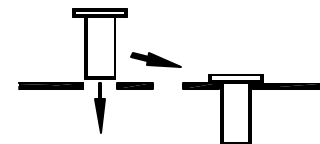

6. Route your cable through the center hole.
7. Place the gasket and light over the well nuts and align the holes in the flanges with the well nuts. Insert the mounting screws and tighten until snug.
8. Connect the cable to an appropriate strobe power supply.

### ONE YEAR LIMITED WARRANTY

The manufacturer warrants each new product, under normal use, against factory defects in material and workmanship for one year after the date of purchase. The owner will be responsible for returning to the Service Center any defective item(s) with the transportation costs prepaid. The manufacturer will, without charge, **repair or replace at its option**, products, or part(s), which its inspection determines to be defective. Repaired or replacement item(s) will be returned to the purchaser with transportation costs prepaid from the service point. A copy of the purchaser's receipt must be returned with the defective item(s) in order to qualify for the warranty coverage.

Exclusions from this warranty include, but are not limited to, bulbs, strobe tubes, domes, and/or the finish. This warranty shall not apply to any light, which has been altered, such that in the manufacturer's judgment, the performance or reliability has been affected, or if any damage has resulted from abnormal use or service. This warranty does not apply to defect or damage occurring as a result of disaster, accident, abuse, misuse, lightning, power surges, or failure to follow instructions in any enclosed manuals. Any damage or defects occurring as a result of any unauthorized service or repairs by unauthorized persons shall be excluded from this warranty.

There are no warranties expressed or implied (including any warranty of merchantability or fitness), which extend this warranty period. **The loss of use of the product, loss of time, inconvenience, commercial loss or consequential damages, including costs of any labor, are not covered.** The manufacturer reserves the right to change the design of the product without assuming any obligation to modify any product previously manufactured.

If a product must be returned for any reason, please contact our Customer Service Department to obtain a Returned Goods Authorization number (RGA #) before you ship the product back. Please write the RGA # clearly on the package near the mailing label.

To obtain warranty service, or if you have any questions concerning this or any other Star product, please contact our **Customer Service Department** at (585) 226-9787.

## Star Headlight & Lantern Co., Inc.

455 Rochester Street Avon, NY 14414

Phone: 585-226-9787 FAX: 888-478-2979



www.starheadlight.com

## Star Headlight & Lantern Co., Inc.

455 Rochester Street Avon, NY 14414

Phone: 585-226-9787 FAX: 888-478-2979



www.starheadlight.com

## Connecting SP3860-2H-OP to: RP966 and RP996 Packs

### All Heads On and Off Together (With High/Low Power Switching Option)

1. Be sure that the **High-Low/3-Pair Head Select Jumper** is in the High-Low position, towards the right. (see RP966/RP996 Owners Manual).
2. Connect the **black** wire from your power plug on the strobe pack and the **black** wire from terminal 3 of SW1 on the switch panel to a good chassis ground.
3. Connect the **black** and **red** wires from the ENABLE plug and the **red** wire from the POWER plug to the **red** wire from SW1 (the On/Off switch).
4. The **white** wire from the ENABLE plug allows utilization of the HI/LO (Day/Night Mode) option. The **white** wire from your ENABLE plug should be connected to the **white** wire from terminal 1 of SW2. When the **white** wire is connected to power through your second switch the pack will run in high power mode. When SW2 is in the "off" or "LOW" position, your pack will operate in "Night Mode" (low power).

The **white** wire from the POWER connector allows you to select the flash pattern you wish to have your strobe pack display. You can scroll through 24 different patterns (listed below) by turning your strobe lights on and briefly touching the **white** POWER wire to +12VDC and releasing it. Continue to briefly touch and release this wire to +12VDC until you find the pattern desired. Once you have the pattern you like, tape the end of the **white** wire from the POWER connector so that it does not come into contact with +12VDC.

1. Simultaneous Singleflash
2. Alternating Single flash
3. Alternating Doubleflash
4. Alternating Tripleflash
5. Alternating Quadflash
6. Alternating Quintflash
7. Double-Duty
8. Doubleflash Alternating, Doubleflash Simultaneous
9. Alternating Climber
10. Leadfoot
11. Singleflash Knight Rider Effect†
12. Quadflash Knight Rider Effect†
13. Doubleflash Left†
14. Doubleflash Right†
15. Quadflash Center Out†
16. Quadflash Warning†
17. Pseudo-Random
18. Delta Omega Sweep
19. Alternating Quadflash & Alternating Single flash Combo
20. Delta Omega Sweep, Alternating Quintflash & Alternating Doubleflash Combo (DEFAULT)
21. Alt. Doubleflash, Simultaneous Doubleflash, Leadfoot, Pseudo-Random & Alt. Quadflash Combo
22. Alternating Climber, Double-Duty, Alternating Quintflash & Alternating Quadflash Combo
23. Cycle Through Patterns 1 - 10, 17 & 18
24. Cycle Through All Patterns

† - Traffic Director type patterns - with only two heads enabled, these patterns will all be Quadflash Warn.

## SP3860-2H-OP

Wiring Diagram for  
New Style RP966/RP996  
On/Off w/High-Low Power Switching  
All heads activate together  
(Set Strobe Pack Jumper in High/Low Option Position)

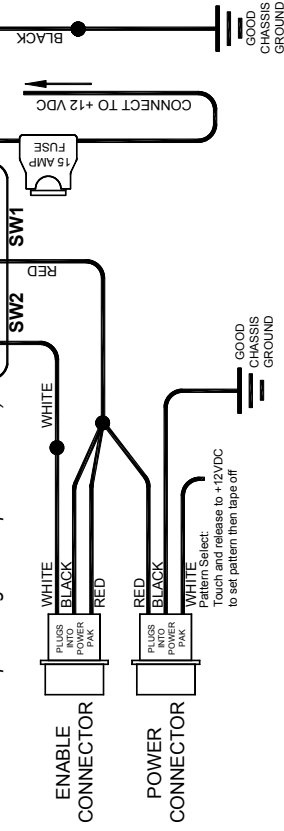

The SP3860-2H-OP can be used with a number of different strobe packs. To properly connect the switch panel, please locate the appropriate section for your application and follow those instructions.



PROUDLY MADE IN THE USA  
An ISO 9001 Certified Company

**STAR**  
WARNING  
SYSTEMS

**Star Headlight & Lantern Co., Inc.**  
455 Rochester Street  
Avon, NY 14414  
Phone: 585-226-9500  
Fax: 888-478-2797  
www.star1889.com

**Signal**  
VEHICLE PRODUCTS™

SINCE 1889  
www.star1889.com

## Connecting SP3860-2H-OP to: Old Style RP242, RP244, and RP906 Packs

(Strobe packs manufactured prior to June 2005 DATE CODE 2205)

1. Connect the **black** wire from your power plug on the strobe pack and the **black** wire from the switch panel to a good chassis ground.
2. Connect the **red** wire from your power plug and all three wires from the CTRL connector to the **red** wire extending from terminal 2 of SW1. This will place your pack into five-flash mode. Please review the strobe pack owner's manual for alternate flash patterns.

**WARNING: DO NOT USE THE FIVE FLASH PATTERN IF YOU ONLY ARE CONNECTING TWO HEADS TO THE RP244 OR RP906. DISCONNECTING THE RED CTRL WIRE WILL PLACE THE PACK INTO QUADFLASH MODE.**

3. The **white** wire from the power plug allows utilization of the HI/LO (Day/Night Mode) option. Connect the **white** wire from your PWR plug to the **white** wire from terminal 1 of the High/Low switch (SW2). When the **white** wire is connected to power through SW2 the pack will operate in "Night Mode" (low power). When SW2 is in the "off" position, your pack will run in high power mode.
4. The **fused lead** from terminal 1 of SW1 on the switch panel will connect to your +12VDC power supply.
5. When properly wired, SW1 will be on the left side (Front View) and switch the pack on and off. SW2 will be located on the right side of the switch panel and will be used to select between low or high power.

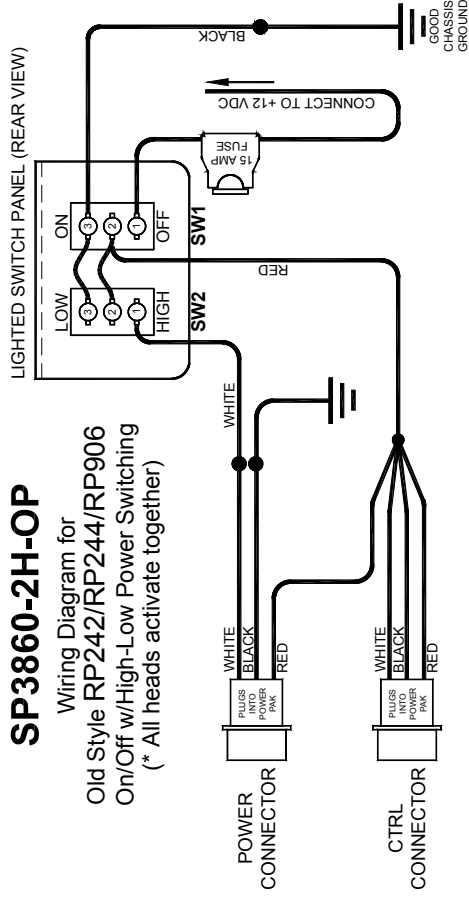

If you have any questions concerning this or any other Star product, please contact our Customer Service Department at (585) 226-9787.

## Connecting SP3860-2H-OP to: New Style RP242 and RP244 Packs

(REV. A strobe packs manufactured since June 2005 DATE CODE 2205)

All Heads On and Off Together  
(With High/Low Power Switching Option)

1. Connect the **black** wire from your power plug on the strobe pack and the **black** wire from the switch panel to a good chassis ground.
2. Connect the **red** wire from your PWR plug and the **black** and **white** wires from the CTRL plug to the **red** wire from terminal 2 of the On/Off switch (SW1).
3. The **white** wire from the PWR plug allows utilization of the HI/LO (Day/Night Mode) option. Connect the **white** wire from your PWR plug to the **white** wire from terminal 1 of the High/Low switch (SW2). When the **white** wire is connected to power through SW2 the pack will operate in "Night Mode" (low power). When SW2 is in the "off" position, your pack will run in high power mode.

The **red** wire from the CTRL connector allows you to select the flash pattern you wish to have your strobe pack display. The pack is defaulted for Five-Flash mode. You can scroll through Pseudo-Random, Singleflash, Doubleflash, Tripleflash, Quadflash, and back to Five-Flash by turning your strobe lights on and briefly touching the **red** CTRL wire to +12VDC and releasing it. Continue to briefly touch and release this wire to +12VDC until you find the pattern desired. Once you have the pattern you like, tape the end of the **red** wire from the CTRL connector so that it does not come into contact with +12VDC.

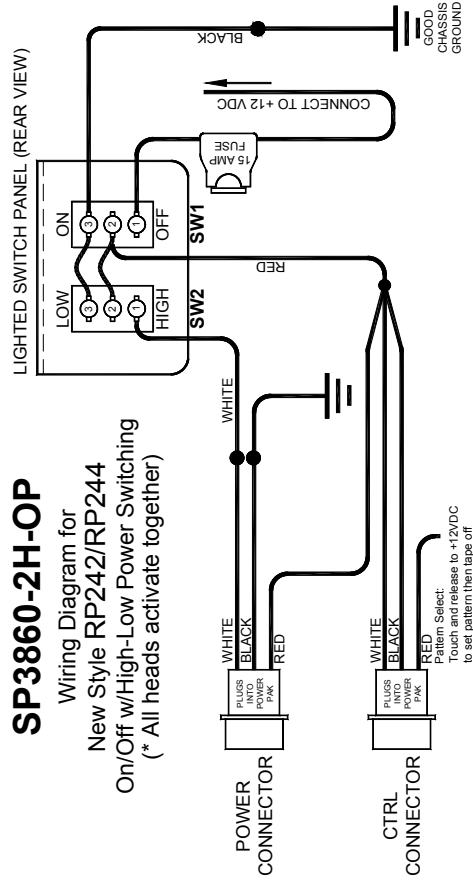

If you have any questions concerning this or any other Star product, please contact our Customer Service Department at (585) 226-9787.