



PROUDLY MADE IN THE USA
An ISO 9001 Certified Company



Strobe
WARNING LIGHTS

REMOTE STROBE PACKS

Models RP966, and RP996

Owner's Manual & Installation Instructions

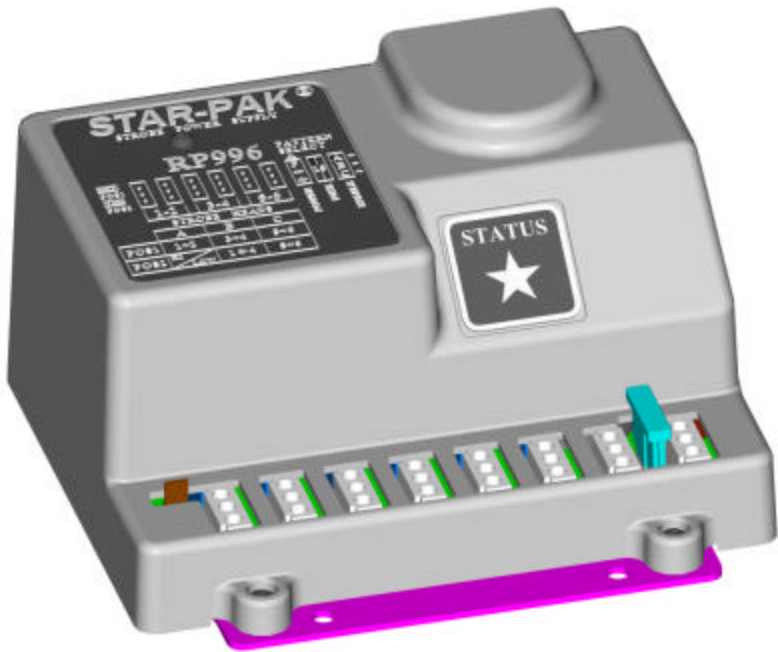

<u>Model</u>	<u># of Heads</u>	<u>Total Watts</u>	<u>Joules per Side</u>	<u>Amps</u>
RP966	6	60	20.7J	7.8A
RP996	6	90	31.1J	9.4A



Star Headlight & Lantern Co., Inc.

455 Rochester Street
Avon, NY 14414



Phone: 585-226-9500
Toll Free Fax: 888-478-2797



www.star1889.com

This page intentionally left blank

Table of Contents

SAFETY WARNINGS	1
MOUNTING	2
WIRING INSTRUCTIONS	3-9
PATTERN SELECTION	8
STATUS LED	10
CONNECTING THE REMOTE HEADS	11
TROUBLESHOOTING	12-13
SERVICE & WARRANTY	14



This light utilizes high-intensity strobe lights. **DO NOT** stare directly into the light while it is on, as momentary blindness and/or permanent eye damage may occur.

- ▶ **IMPORTANT:** Please read all of the following instructions before installing your new strobe system. This instruction sheet applies only to the models listed.
- ▶ **CAUTION:** All of our remote power supplies are polarity sensitive. They are polarity protected *only if the appropriate fuse* is used. All wires connected to the positive terminal of the battery should be fused at the battery for their rated load. **Testing the system before this fuse is properly installed will void the warranty on the light.**
- ▶ **Opening or tampering with your remote power supply will void the warranty.** The remote power supply must be mounted against a smooth metal surface in a dry location. **Water damage to the power supply will also void the warranty.** Typical mounting locations of your power supply include the interior firewall, beneath the seat of a truck, or inside a large toolbox.

NOTICE

Due to continuous product improvements, we must reserve the right to change any specifications and information, contained in this manual at any time without notice. Star Headlight & Lantern Co., Inc. makes no warranty of any kind with regard to this manual, including, but not limited to, the implied warranties of merchantability and fitness for a particular purpose. Star Headlight & Lantern Co., Inc. shall not be liable for errors contained herein or for incidental or consequential damages in connection with the furnishing, performance, or use of this manual.

Mounting

Mount the pack on a smooth metal surface to allow for adequate heat dissipation. Do not mount the pack near any external heat source, as this will retard its ability to dissipate heat sufficiently. Mount the pack using four bolts (not included). When mounting, make sure a good electrical connection exists between the mounting plate and the vehicle chassis. This will help to eliminate any RF interference.



When mounting the power pack and accessories, please be sure to keep any radio frequency sensitive equipment at least 20" from the power pack, cables, and/or wires which make up your strobe system. The pack has been designed to limit RFI emissions, but certain very sensitive equipment may still be affected. Symptoms may include, but are not limited to, sporadic operation and degraded performance. Star Headlight & Lantern Co., Inc. cannot assume any responsibility for any radio frequency induced malfunction or damage to any radios, sirens, lightbars, or any other equipment mounted within 20" of this strobe system. Any antennae mounted in the proximity of the system may cause your radio to suffer the aforementioned results.

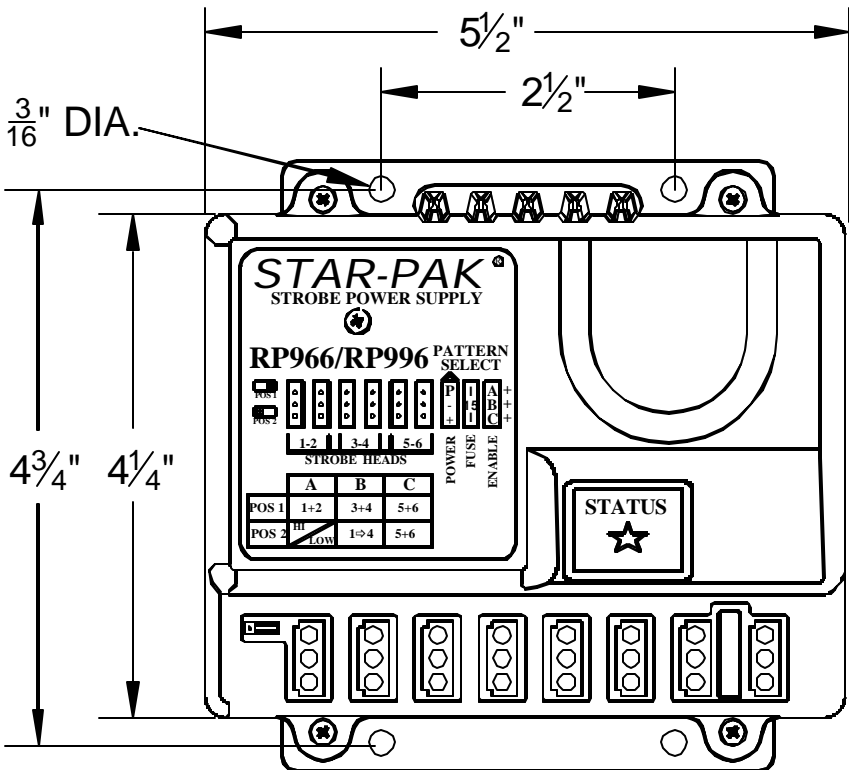

Wiring

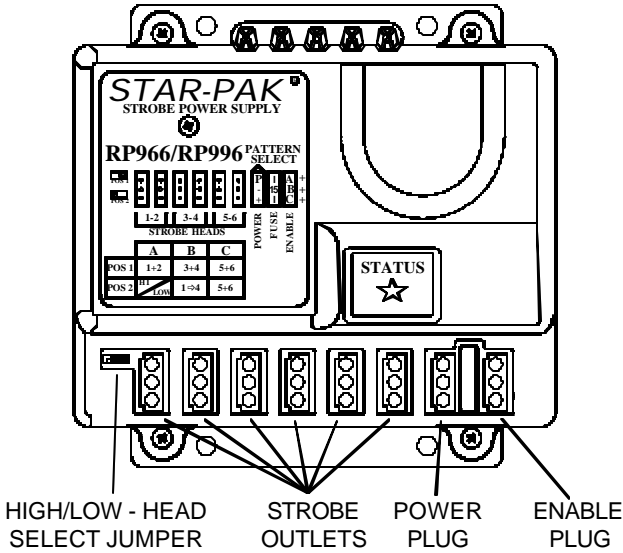

POWER Plug

The power plug is included with your power pack and comes complete with an 8-12" wiring harness. This will be connected to the outlet on your pack labeled **POWER**.

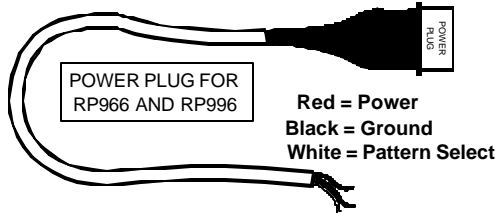

ENABLE Plug

These strobe packs also utilize another plug, identical to the Power Plug, which plugs into the jack labeled **ENABLE**. The connection of the ENABLE wires will allow you to set the pack up in a number of different configurations. Here are the different configurations you may choose from when installing the RP966 and RP996 packs:

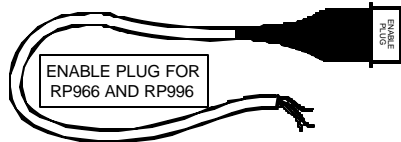

<u>Wire Color</u>	<u>Jumper Set For 3-Pair Head Select</u>	<u>Jumper Set For High/Low Option</u>
Red	= Enable Heads 5 & 6	Enable Heads 5 & 6
Black	= Enable Heads 3 & 4	Enable Heads 1, 2, 3, & 4
White	= Enable Heads 1 & 2	High/Low Option Switching

- All 6 Heads On and Off Together (*High Power Only*)
- All 6 Heads On and Off Together (*Low Power Only*)
- All 6 Heads On and Off Together (*High/Low switching Option*)
- 2-Heads/4-Heads Separate Activation (*High Power Only*)
- 2-Heads/4-Heads Separate Activation (*Low Power Only*)
- 2-Heads/4-Heads Separate Activation (*High/Low Switching Option*)
- 3-Pair Separate Activation (*High Power Only*)

Decide which configuration will work best for you, set your jumper accordingly (see next page), and proceed to the appropriate section to connect the wires from the POWER and ENABLE connectors.

Setting the High/Low – Head Select Jumper

The RP966 and RP996 remote strobe packs allow you to choose whether you would prefer to have the ability to switch three pairs of heads On/Off separately OR if you would like the ability to switch between High and Low power, switching two heads separate from the other four heads. Prior to installation, you should decide which setting will work best for you, and set the jumper appropriately.

LEFT POSITION

If you wish to activate three separate pairs of heads independently of each other, leave the *Head Select - High/Low Jumper* in the **3-Pair Head Select** position (*default*) shown below. The jumper should be on the left two pins, closest to the edge of the pack. The ENABLE wires will function as follows:

White = Enable Heads 1 & 2

Black = Enable Heads 3 & 4

Red = Enable Heads 5 & 6

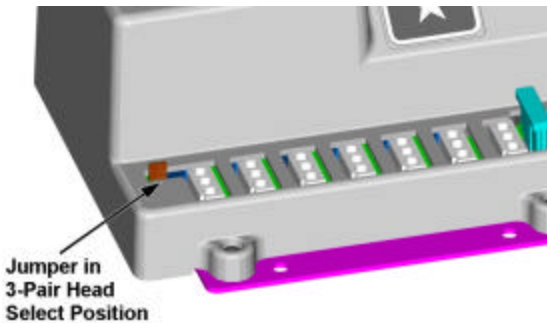

RIGHT POSITION

If you would like to utilize both high and low power, or you will be activating all 6 of your strobe heads together with one On/Off switch, or if you will be activating two heads independently of the other four heads and do not need to operate three different pairs of heads, the jumper should be moved to the right two pins, towards the center of the pack. This will allow you to switch one pair of heads on one switch, the other four heads on another switch, and select high or low power on a third switch. The ENABLE wires will function as follows:

Black = Enable Heads 1, 2, 3, & 4

Red = Enable Heads 5, & 6

White = High/Low Option Switching

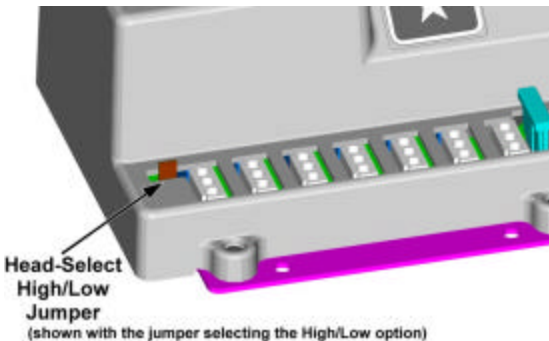

All Heads On and Off Together (High Power Only)

(This setup is typically used for most "On/Off" applications)

For this set up, only one On/Off switch (*not included*) is necessary.

1. Connect the **black** wire from the POWER connector to a good chassis ground.
2. Connect all three wires (**red, black, and white**) from the ENABLE plug and the **red** wire from the POWER connector to a +12VDC power source through your On/Off switch.
3. The **white** wire from the POWER connector will be left unconnected for now. Once your system is installed, the white wire will be used to program the flash pattern. Proceed to the **Pattern Selection** section on page 8.

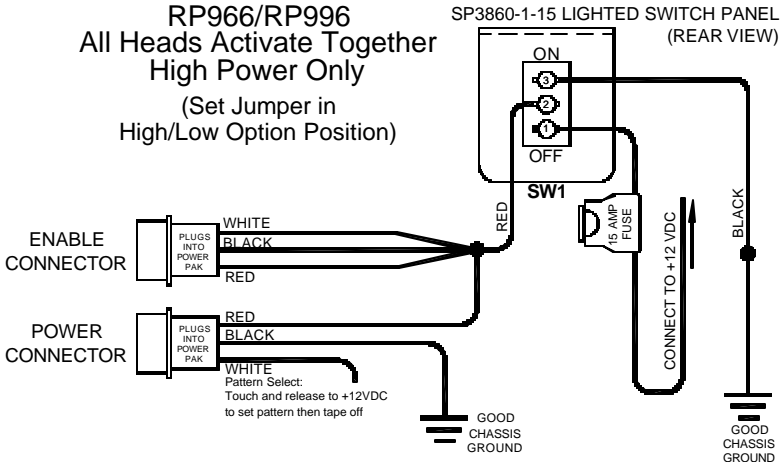

All Heads On and Off Together (Low Power Only)

For this set up, only one On/Off switch (*not included*) is necessary.

1. Connect the **black** wire from the POWER connector and the **white** wire from your ENABLE plug to a good chassis ground.
2. Connect the **red** and **black** wires from the ENABLE plug and the **red** wire from the POWER connector to a +12VDC power source through your On/Off switch.
3. The **white** wire from the POWER connector will be left unconnected for now. Once your system is installed, the white wire will be used to program the flash pattern. Proceed to the **Pattern Selection** section on page 8.

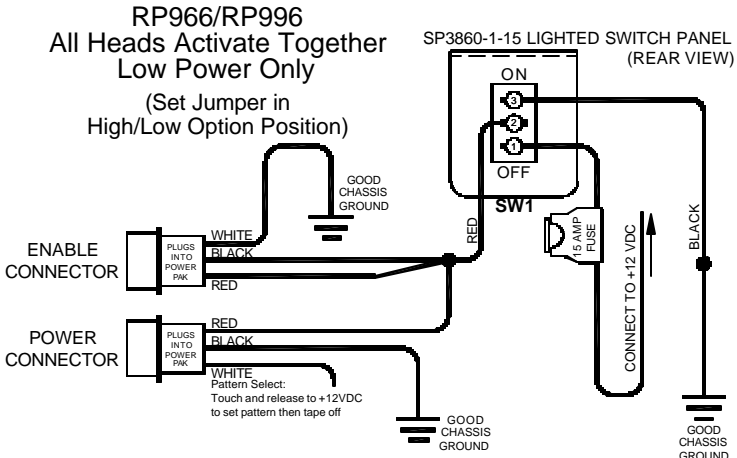

All Heads On and Off Together
(With High/Low Power Switching Option)

1. Use Star Model #SP3860-2H-OP switch panel (*not included*), or any other standard two-switch switch panel capable of delivering 15 amps.
2. Connect the **black** wire from the POWER connector to a good chassis ground.
3. Connect the **black** and **red** ENABLE plug wires and the **red** POWER plug wire to +12VDC through the first On/Off switch.
4. The **white** wire from the ENABLE plug allows utilization of the High/Low (Day/Night Mode) option. The **white** wire from your ENABLE plug should be connected to the second switch. When the **white** wire is connected to power through your second switch, the pack will run in high power mode. When the second switch is in the "off" position, your pack will operate in "Night Mode" (low power).
5. The **white** wire from the POWER connector will be left unconnected for now. Once your system is installed, the white wire will be used to program the flash pattern. Proceed to the **Pattern Selection** section on page 8.

RP966/RP996
All Heads Activate Together
With High/Low Option
 (Set Jumper in High/Low Option Position)

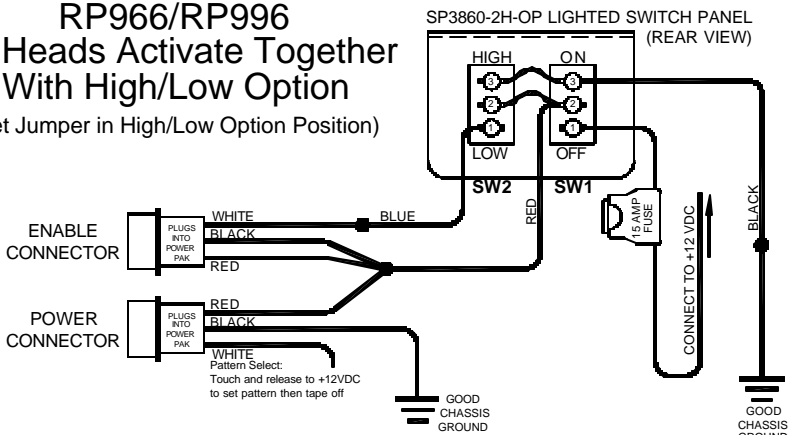

2-Head/4-Head Separate Activation (High Power Only)
 (diagram on next page)

1. For this set up only two On/Off switches are necessary (*not included*). Use Star Model #SP3860-2 switch panel, or any other standard two-switch switch panel capable of delivering 15 amps.
2. Connect the **black** wire from the POWER connector to a good chassis ground.
3. Connect the **red** wire from the ENABLE plug to +12VDC through your first switch.
4. Connect the **black** wire from the ENABLE plug to +12VDC through your second switch.
5. Connect the **red** wire from the POWER plug and the **white** wire from the ENABLE plug to +12VDC through a 15 amp fuse (*not included*).

Please Note: When the red POWER wire is connected to +12VDC the pack will draw a small current (50 mA). If your vehicle will be sitting for extended periods of time (*i.e.* more than a few days), it is recommended that all +12VDC wires be routed through an ignition switched power source.

6. The **white** wire from the POWER connector will be left unconnected for now. Once your system is installed, the white wire will be used to program the flash pattern. Proceed to the **Pattern Selection** section on page 8.

2-Head/4-Head Separate Activation (High Power Only) (CONT'D)

RP966/RP996 Two-Head/Four-Head Switching High Power Only

(Set Jumper in High/Low Option Position)

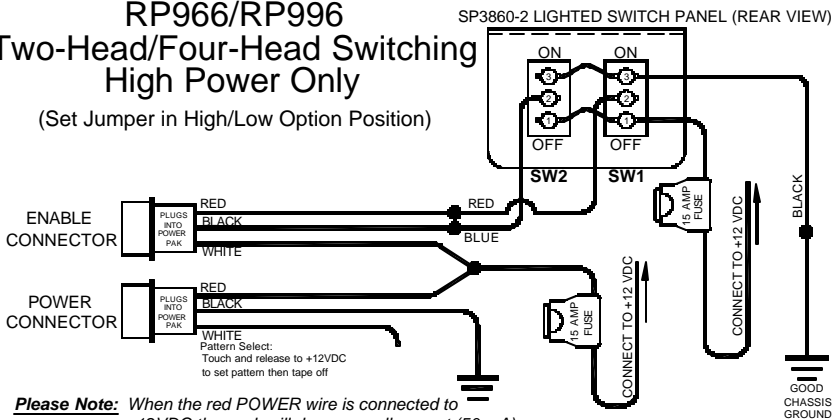

Please Note: When the red POWER wire is connected to +12VDC the pack will draw a small current (50 mA). If your vehicle will be sitting for extended periods of time (i.e. more than a few days), it is recommended that all +12VDC wires be routed through an ignition switched power source.

2-Head/4-Head Separate Activation (Low Power Only)

1. For this set up, only two On/Off switches are necessary (not included). Use Star Model #SP3860-2 switch panel, or any other standard twoswitch switch panel capable of delivering 15 amps.
2. Connect the **black** wire from the POWER connector and the **white** wire from the ENABLE plug to a good chassis ground.
3. Connect the **black** wire from the ENABLE plug to +12VDC through your second switch.
4. Connect the **red** wire from the ENABLE plug to +12VDC through your first switch.

Please Note: When the red POWER wire is connected to +12VDC the pack will draw a small current (50 mA). If your vehicle will be sitting for extended periods of time (i.e. more than a few days), it is recommended all +12VDC wires be routed through an ignition switched power source.

5. The **white** wire from the POWER connector will be left unconnected for now. Once your system is installed, the white wire will be used to program the flash pattern. Proceed to the **Pattern Selection** section on page 8.

RP966/RP996 Two-Head/Four-Head Switching Low Power Only

(Set Jumper in High/Low Option Position)

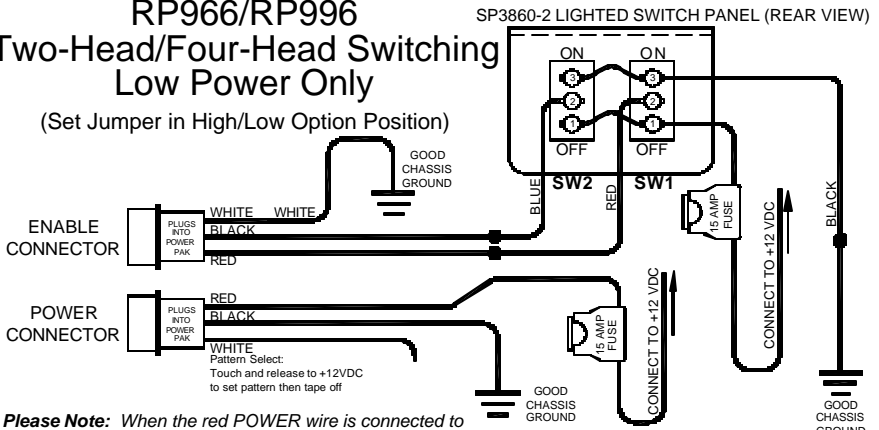

Please Note: When the red POWER wire is connected to +12VDC the pack will draw a small current (50 mA). If your vehicle will be sitting for extended periods of time (i.e. more than a few days), it is recommended that all +12VDC wires be routed through an ignition switched power source.

2-Head/4-Head Separate Activation (With High/Low Power Switching Option)

or

3-Pair Independent Activation (High Power Only)

(diagram on next page)

1. Use Star Model #SP3860-3 switch panel (*not included*), or any other standard three-switch switch panel capable of delivering 15 amps.
2. Connect the **black** wire from the POWER connector to a good chassis ground.
3. Connect the **red** wire from the ENABLE plug to +12VDC through your first switch.
4. Connect the **black** wire from the ENABLE plug to +12VDC through your second switch.
5. Connect the **white** wire from the ENABLE plug to +12VDC through your third switch.

If the Head Select/High-Low Jumper is in the High/Low position: (see page 4)

The **white** wire from the ENABLE plug allows utilization of the High/Low (Day/Night Mode) option. The **white** wire from your ENABLE plug should be connected to the third switch. When the white wire is connected to power through your third switch, the pack will run under high power (Day Mode). When the third switch is in the "off" position, your pack will operate under low power (Night Mode).

If the Head Select/High-Low Jumper is in the 3-Pair Head Select position: (see page 4)

The pack will run under high power and each switch will control one pair of heads.

6. The **white** wire from the POWER connector will be left unconnected for now. Once your system is installed, the white wire will be used to program the flash pattern. Proceed to the **Pattern Selection** section on below.

Pattern Selection

1. The white wire on the POWER cable for the RP966 and RP996 packs allows you to select what pattern you would like the strobe heads to exhibit.
2. Once your switch, strobe pack, cables, and heads are installed, activate your strobe system by turning all the switches on.
3. Using the white wire on the POWER cable, select your flash pattern by slowly touching it to +12VDC for about two seconds and releasing it. Continued touching for two seconds and releasing of the white wire to +12VDC will scroll through the following 24 different patterns:

- | | |
|--|--|
| 1. Simultaneous Singleflash | 14. Doubleflash Right † |
| 2. Alternating Single flash | 15. Quadflash Center Out † |
| 3. Alternating Doubleflash | 16. Quadflash Warning † |
| 4. Alternating Tripleflash | 17. Pseudo-Random |
| 5. Alternating Quadflash | 18. Delta Omega Sweep |
| 6. Alternating Quintflash | 19. Alternating Quadflash & Alternating Single flash Combo |
| 7. Double-Duty | 20. Delta Omega Sweep, Alternating Quintflash & Alternating Doubleflash Combo (DEFAULT) |
| 8. Doubleflash Alternating, Doubleflash Simultaneous | 21. Alt. Doubleflash, Simultaneous Doubleflash, Leadfoot, Pseudo-Random & Alt. Quadflash Combo |
| 9. Alternating Climber | 22. Alternating Climber, Double-Duty, Alternating Quintflash & Alternating Quadflash Combo |
| 10. Leadfoot | 23. Cycle Through Patterns 1 - 10, 17 & 18 |
| 11. Singleflash Knight Rider Effect † | 24. Cycle Through All Patterns |
| 12. Quadflash Knight Rider Effect † | |
| 13. Doubleflash Left † | |

† - Traffic Director type patterns - with only two heads enabled, these patterns will all be Quadflash Warn.

4. Once you have found the desired pattern, you can turn off the system. The strobe pack will "remember" the last selected pattern when switched off and that pattern will be displayed the next time the pack is switched on. Tape or place a wirenut over the end of the white wire to prevent it from coming into contact with +12VDC again.
5. **OPTIONAL:** If you wish to utilize your own remote pattern select switch, you may connect the white wire to +12VDC through a momentary on/off switch (user supplied).

RP966/RP996

Two-Head/Four-Head Switching or Three-Pair Independent Switching (With High/Low Option)

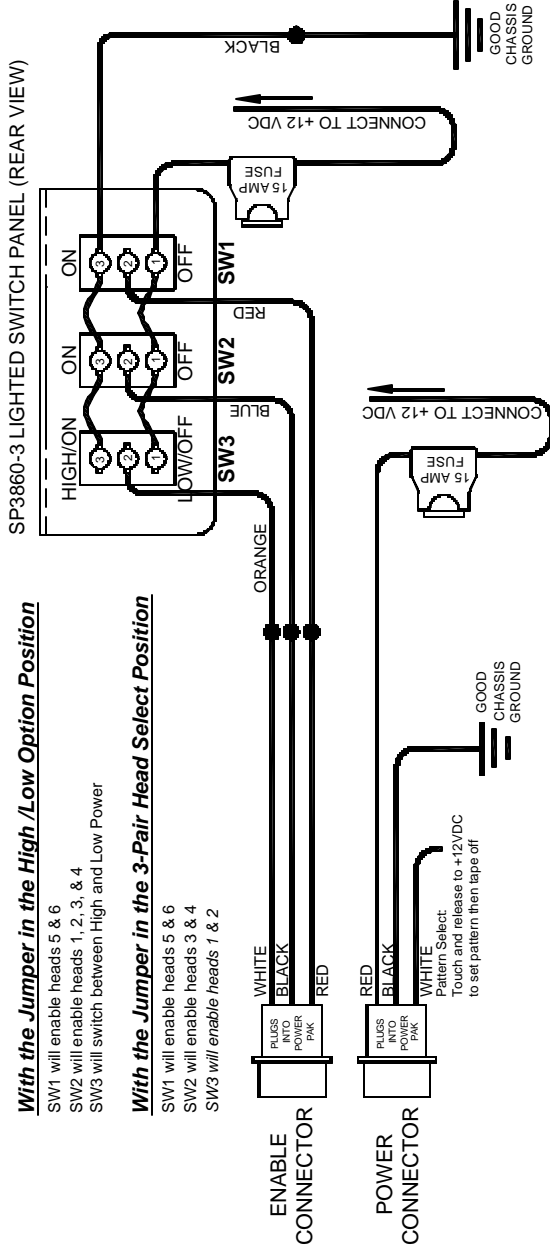

With the Jumper in the High /Low Option Position

- SW1 will enable heads 5 & 6
- SW2 will enable heads 1, 2, 3, & 4
- SW3 will switch between High and Low Power

With the Jumper in the 3-Pair Head Select Position

- SW1 will enable heads 5 & 6
- SW2 will enable heads 3 & 4
- SW3 will enable heads 1 & 2

Please Note: When the red POWER wire is connected to +12VDC the pack will draw a small current (50 mA). If your vehicle will be sitting for extended periods of time (i.e. more than a few days), it is recommended that all +12VDC wires be routed through an ignition switched power source.

Status LED

1. The RP966 and RP996 power packs come with a built-in “star-shaped” status LED.
2. When operating properly, the LED will blink in conjunction with each of the strobe heads.
3. If none of the heads are flashing and the Star LED is a dim steady burn, proper voltage is reaching the POWER cable, but is not reaching the ENABLE cable. Check that your switches are on and that +12VDC is reaching the ENABLE wires.
4. The Star LED is also designed to flicker when there are no active strobe heads flashing during a particular flash cycle. If none of the heads are flashing and the LED is flickering, all of the heads are bad or they are all wired incorrectly.
5. If none of the heads are flashing and the Star LED single flashes every 1-3 seconds then the pack is receiving insufficient voltage (below 11.0 volts).

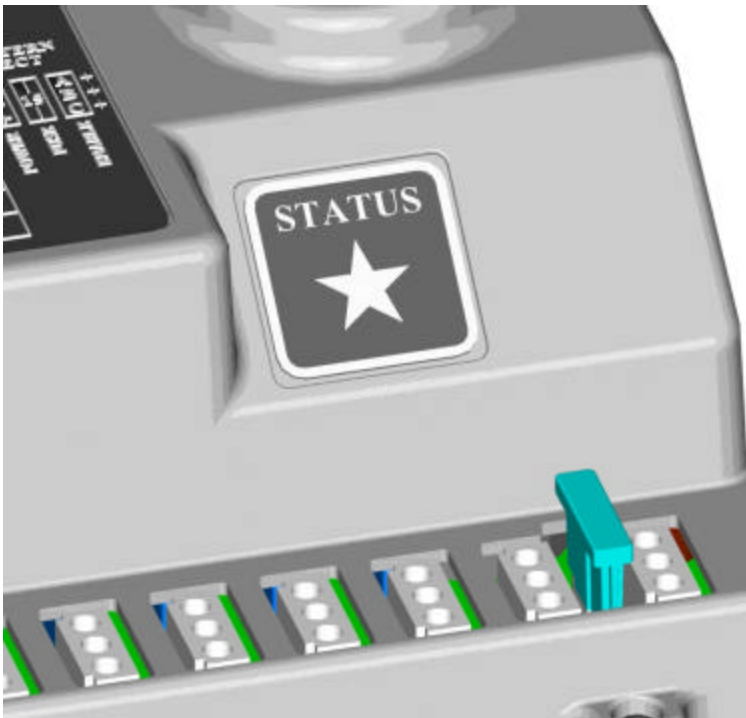

Connecting the Remote Heads:

1. Cable is required to connect the power pack to your remote strobe heads. Cable can be purchased from Star:

Length (ft)	Shielded Cable	SO Cable
	w/Amp Connector	w/Weatherproof Connector
15	4415	3814-180"
20	4420	3814-240"
25	4425	3814-300"
30	4430	3814-360"
35	N/A	3814-420"

Length (ft)	Shielded Cable	SO Cable
	w/Amp Connector	w/Weatherproof Connector
40	N/A	3814-480"
45	N/A	3814-540"
50	N/A	3814-600"
55	N/A	3814-660"
60	N/A	3814-720"

2. If you intend to use your own cable for connecting the remote heads, it must meet the following specifications: It must be three-conductor with 600V insulation, it must be a minimum 18 AWG for 0-30 ft. or 16 AWG for 31-60 ft., and it should be UV stabilized. Star does not recommend the use of any cable length greater than 60 feet, as the resistance may cause a drop in voltage resulting in inconsistent or complete loss of firing in the heads. Please use the Table below for proper cable sizes.

Remote Power Pack Cabling Requirements

		0-20 ft.	21-30 ft.	31-60 ft
Input Power and Ground Wires	<i>RP966:</i>	16 AWG	14 AWG	12 AWG
	<i>RP996:</i>	14 AWG	12 AWG	10 AWG
Wires to Remote Heads		18 AWG	18 AWG	16 AWG
Enable Wires		18 AWG	18 AWG	18 AWG

3. If you are using your own cable and need connectors to attach the cable to the power pack, order part **#CK473**. The #CK473 consists of one connector (30041-20) and three male terminals (30042-16). This is also the replacement connector for any remote heads with the white AMP connectors (NOT weatherproof).
4. The AMP connector, found on the cables, which mates to the CK473 is a kit **#CK472**. The #CK472 consists of one connector (448) and three female terminals (30042-15).
5. If you need a weatherproof connector kit for your cable to attach to our remote strobe heads, please order part **#CK702**. This kit contains one connector (30185-3), three female terminals (30042-30), and three rubber seals (30186-2).
6. If you need to order a weatherproof connector kit for your strobe head to mate with the connector on your cable (#CK702), please order part **#CK703**. This kit contains one connector (30185-4), three male pins (30042-29), and three rubber seals (30186-2).
7. For good, reliable connections between the cable system and the strobe heads in various weather and contamination conditions, it is strongly recommended that dielectric grease be used on the connectors. It should be applied to the rear of the connectors, where the wires enter, as well as into each terminal area where the connectors mate, before joining the two connectors together. We have found this procedure to be effective even under the most extreme of conditions. **Do Not Seal The Connectors Using Silicon Or RTV.**



CAUTION: High voltages exist in electronic strobe lights. Before attempting service on any strobe light, be sure to disconnect the power for at least five minutes to allow the capacitor to discharge. Failure to heed this warning may result in severe electrical shock and/or injury.

Please Note: Most strobe and rotating beacon failures can be traced to wiring and battery problems. Before attempting any service on the circuit itself, please be sure to check all connections and wiring to ensure the correct voltage and/or polarity is reaching your light or remote head.

TROUBLESHOOTING GUIDE

If a problem exists in only one head, a strobe tube may have burned out, or there may be an open electrical connection in the wiring harness or strobe head. Check connections at and between the strobe pack and the strobe head, including all wiring. Replace the malfunctioning heads and/or wiring harnesses if necessary.

If none of your heads are flashing, follow these steps to determine the problem:

1. **Check all fuses**, including those at the battery, at the switch panel, in the dash, and on the pack (if applicable). The RP966 and RP996 have automotive “blade” type fuses. Remove these fuses, and check them to confirm they have not blown. Replace any blown fuses with only fuses of identical values. Replacing the fuse with the wrong rating may damage your pack and/or vehicle, and will void your warranty.
2. **Check the power and ground wires to your pack.** With the vehicle turned off and while the pack is running, measure the voltage across the red wire (pin 1) and the black wire (pin 2) of the **POWER** connector on the strobe pack. Push the probes of the test meter down into the connector at the wire entry points to contact the terminals for the measurement. A nominal 13.8 volts should be present. Low voltage to the pack can cause erratic flashing or even complete failure of the heads. A minimum of 11.0 volts should be present for the pack to operate properly.
If you do not have proper voltage present your power or ground is bad. Skip to the section on **Checking a Bad Power or Ground Connection.** If your pack is receiving sufficient voltage then continue to step 3.
3. **Check the Power connector to be sure that +12VDC is not applied to the white wire.** The white wire is used for pattern select. The patterns are changed by touching AND RELEASING this wire to +12VDC. A constant voltage applied to the white wire on the Power connector will prevent the strobe pack from flashing.
4. **Check that the proper voltage is reaching the necessary ENABLE inputs.**
The black and red wires on the ENABLE plug should have +12VDC. The white wire should also have +12VDC if the jumper is set for 3-Pair Head Select (see pages 4 and 9).

5. **Check each head.** If the leads in one of the heads have shorted out, the output voltage of the other heads may be held down as well. To test for this, unplug all of the heads and plug them in individually (one at a time). If your problem is a result of a shorted head, then each good head should function properly when connected by itself. Note: A *burned out* strobe tube does not cause a short and will not affect the operation of the remaining heads. If the problem is not with a shorted head and if proper voltage is reaching the pack, the problem is most likely internal to the pack. Call Star to obtain an R.G.A. number to return the pack for service.

Checking a Bad Power or Ground Connection

If sufficient voltage is not reaching the pack, perform the following tests:

1. **Test Power at the Battery:** With the vehicle turned off and while the pack is running, measure the battery voltage at the battery. A nominal 13.8 volts should exist. If this voltage is below 11.0 volts, the pack will not function properly and the problem is with the battery. This reading should not be more than 1.25 volts higher than the reading at the strobe pack itself.
2. **Test the Power Wire Between the Battery and the Switch:** Move to the ON/OFF switch in the cab and gain access to the rear of the switch panel. With the vehicle not running and the pack on at the high power setting, measure the voltage drop in the red wire by taking a reading with one probe on the positive side of the battery and the other probe in pin 1 of your switch. If this reading exceeds 0.25 volts then there is a poor connection between the switch and the battery in the red wire and it should be checked. **NOTE:** *Excessive voltage drop may be occurring in the connections on the switch panel. If you have one of our switches you can increase the contact pressure by removing the FASTON terminal from the tab on the switch. Using long nose pliers, gently squeeze the FASTON terminal together in the area that slides on to the tab of the switch. This will increase the pressure applied between the tabs and the connector and reduce voltage drop.*
3. **Test the Power Wire Between the Strobe Pack and the Switch:** This same procedure can be used to check the wires between the switch panel and the pack. Place one probe on the terminal at the switch and the other probe into the terminal with the corresponding wire color in the **PWR** connector on the pack. Once again, if any of the readings exceed 0.25 volts then you should check those wires and their connections.
4. **Test your Ground Wire:** If you still have not located the problem, troubleshoot the connections between the good chassis ground and pin 2 (black or blue wire) of the **PWR** connector on the power pack. With the vehicle not running and the pack on at the high power setting, measure the voltage drop in the Black (Ground) wire by taking a reading with one probe on the negative side of the battery and the other probe in pin 2 of your **PWR** connector. If this reading exceeds 0.25 volts then you have a bad Ground.



ONE YEAR LIMITED WARRANTY

*The manufacturer warrants each new product, under normal use, against factory defects in material and workmanship for one year after the date of purchase. The owner will be responsible for returning to the Service Center any defective item(s) with the transportation costs prepaid. The manufacturer will, without charge, **repair or replace at its option**, products, or part(s), which its inspection determines to be defective. Repaired or replacement item(s) will be returned to the purchaser with transportation costs prepaid from the service point. A copy of the purchaser's receipt must be returned with the defective item(s) in order to qualify for the warranty coverage.*

Exclusions from this warranty include, but are not limited to, bulbs, strobe tubes, domes, and/or the finish. This warranty shall not apply to any light, which has been altered, such that in the manufacturer's judgment, the performance or reliability has been affected, or if any damage has resulted from abnormal use or service. This warranty does not apply to defect or damage occurring as a result of disaster, accident, abuse, misuse, lightning, power surges, or failure to follow instructions in any enclosed manuals. Any damage or defects occurring as a result of any unauthorized service or repairs by unauthorized persons shall be excluded from this warranty.

There are no warranties expressed or implied (including any warranty of merchantability or fitness), which extend this warranty period. **The loss of use of the product, loss of time, inconvenience, commercial loss or consequential damages, including costs of any labor, are not covered.** The manufacturer reserves the right to change the design of the product without assuming any obligation to modify any product previously manufactured.

This warranty gives you specific legal rights. You might also have additional rights that may vary from state to state. Some states do not allow limitations on how long an implied warranty lasts. Some states do not allow the exclusion or limitation of incidental or consequential damages. Therefore, the above limitation(s) or exclusion(s) may not apply to you.

If you have any questions concerning this or any other product, please contact our **Customer Service Department** at (585) 226-9787.

If a product must be returned for any reason, please contact our Customer Service Department to obtain a Returned Goods Authorization number (RGA #) before you ship the product to Star. Please write the RGA # clearly on the package near the mailing label.



Star Headlight & Lantern Co., Inc.

455 Rochester Street
Avon, NY 14414



Phone: 585-226-9500
Toll Free Fax: 888-478-2797

www.star1889.com



MODEL ST415P*

REMOTE STROBE HEAD INSTALLATION

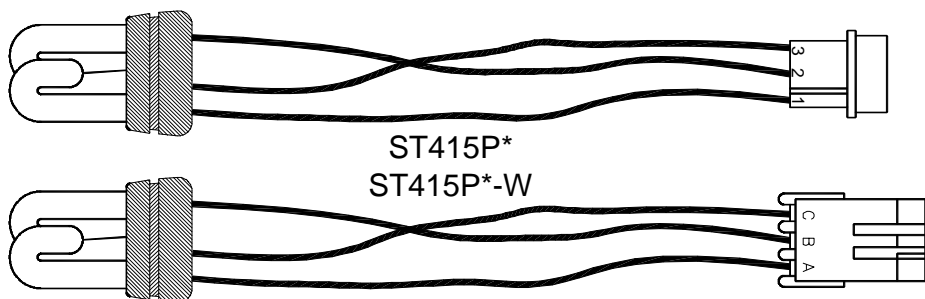

The ST415P series strobe heads are designed for use as an auxiliary warning light system. They **will not** replace your current headlights or Stop-Tail-Turn lights, but instead will provide an independent, supplementary warning signal.



WARNING!

These are HIGH INTENSITY strobes. DO NOT stare directly into the light while it is on, as momentary blindness and/or permanent eye damage may occur.

SAFETY MESSAGE TO INSTALLERS

People's lives depend on your safe installation of our products. It is important to read, understand and follow all instructions shipped with our products. In addition, listed below are some other important safety instructions and precautions you should follow:

- To properly install this warning light: you must have a good understanding of automotive electrical procedures and systems, along with proficiency in the installation and use of safety warning equipment.
- When drilling into a vehicle structure, be sure that both sides of the surface are clear of anything that could be damaged.
- DO NOT install equipment or route wiring or cords in the deployment path of an air bag.
- DO NOT attempt to activate the light while driving in a hazardous situation.
- File this instruction sheet in a safe place and refer to it when maintaining and/or reinstalling the product.

Failure to follow all safety precautions and instructions may result in property damage, serious injury, or death to you or others.

1. The remote strobe head *must* be connected to a power pak to operate. You may use our two-outlet, four-outlet, or six-outlet paks. These heads may *or may not work* with alternate brand power paks. The installer accepts any and all liability if this head is used in conjunction with any unapproved power paks.
2. Locate the light housing you wish to install the head into. If necessary, disassemble the light housing on the vehicle such that you can gain access to the back of the reflector.
3. Select a location suitable to mount your strobe head. The ideal location is as close to the focal point of the reflector as possible. The strobe head must be located at least 1" from any other lights, the lens, and the lens housing, to allow for adequate heat dissipation.
4. ***After you have checked that both sides of the mounting surface are clear***, drill a 1" hole in the reflector. Be sure to debur both sides of the hole to allow for easier insertion and so that there is a clean, smooth surface for the strobe head to seal against.
If you have a double walled housing (ie. an outer wall in addition to the inner reflector wall), you will need to drill through both surfaces to properly mount your new strobe head. Using a hole saw, drill a 1 1/4" hole in the outer wall. Once through the outer wall, the pilot drill bit from the hole saw should start the pilot hole in the inner wall. Using the pilot hole for centering, drill a 1" hole in the inner wall. Be sure to de-bur both sides of the hole to allow for easier insertion and so that there is a clean, smooth surface for the strobe head to seal against. It might be necessary to cover the 1 1/4" hole you drilled in the outer wall to prevent contaminants getting inside the housing.
5. To insert the strobe head, hold the rubber base with your thumb and forefinger. Slowly twist the base while you push it into the 1" hole. Twisting while pushing helps the cup to slide into the hole easier and helps ensure the lip on the rubber base "pops" into place around the rubber housing.
6. Once the strobe head is installed, reassemble the light.
7. Attach the enclosed connector to the head by snapping the terminals on each wire into the proper slot. Review the diagram below.

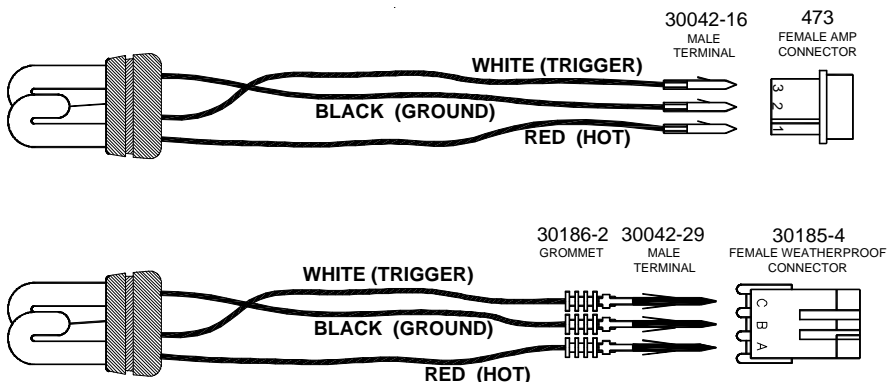

8. Once the installation of the heads is complete, connect them to your power pak using the proper cable:

	Amp Connector	Weatherproof Connector
Light Duty Cable	3821	3820
Heavy Duty Cable	N/A	3814
Shielded Cable	4415	N/A

9. If you intend to use your own cable, it must meet certain specifications as follows: It must be three-conductor with 600V insulation, minimum 18 AWG for 0-20 ft., 16 AWG for 21-30 ft. or 14 AWG for 31-60 ft. We do not recommend the use of any cable length greater than 60 feet, as the resistance might cause a drop in voltage resulting in inconsistent or complete loss of firing in the heads.

10. For good, reliable connections between the cable system and the strobe head in various weather and contamination conditions, it is strongly recommended that a dielectric grease be used on the connectors. It should be applied and into each terminal area where the connectors mate, before joining the two connectors together. We also recommend applying dielectric grease to the back of each connector where the wires enter. We have found this procedure to be effective even under the most extreme of conditions. **Do Not Seal The Connectors Using Silicon Or RTV.**
11. If you must remove the white amp connector for any reason, please re-insert the wires back into their proper location. Please refer to the diagram below. If you need to order another amp connector kit, please use part #CK473. This kit contains one connector (473) and three male pins (30042-16).

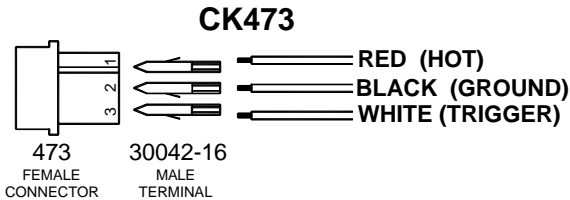

12. If you need to order a white amp connector kit to mate with the CK473 (the connector on your strobe head), please use part #CK472. This kit contains one connector (448) and three female pins (30042-15).

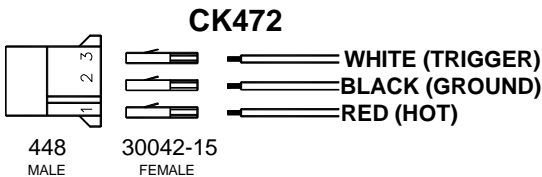

13. If you must remove the weatherproof connector for any reason, please re-insert the wires back into their proper location. Please refer to the diagram below. If you need to order another weatherproof connector kit, please use part #CK703. This kit contains one connector (30185-4), three male pins (30042-29), and three rubber seals (30186-2).

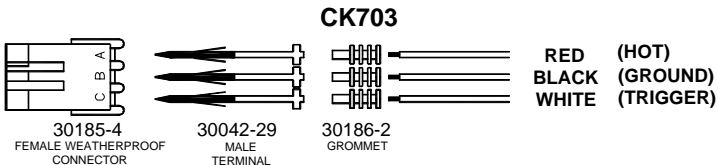

14. If you need to order a weatherproof connector kit to mate with the CK703 (the connector on your strobe head), please use part #CK702. This kit contains one connector (30185-3), three female pins (30042-30), and three rubber seals (30186-2).

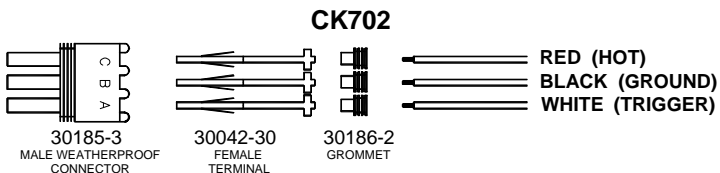

Please Note: These instructions are provided as a general guideline only. Specific mounting, wiring, and/or weather-sealing may be necessary and are the sole responsibility of the installer. The manufacturer assumes no responsibility for the integrity of the installation for this or any of its products.



CAUTION: High voltages exist in electronic strobe lights. Before attempting service on any strobe light, be sure to disconnect the power for at least five minutes to allow the capacitor to discharge. Failure to heed this warning may result in severe electrical shock and/or injury.

Please Note: Most strobe and rotating beacon failures can be traced to wiring and battery problems. Before attempting any service on the circuit itself, please be sure to check all connections and wiring to ensure the correct voltage and/or polarity is reaching your light or remote head.

CK473

1. Enclosed you will find a kit containing 1 cable-side connector and 3 male pins.
2. Cut off the old connector from the cable on your vehicle, if present.
3. Strip 1½"-2" of the outer insulation off exposing the three inner wires.
4. These wires should be stripped each about ¼".

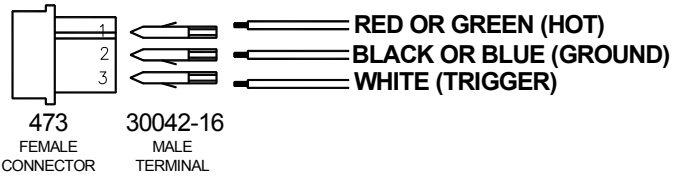

5. Secure each terminal by crimping the large tabs around the insulation and the
6. After checking that your crimps are secure, insert the terminals into the correct holes in the connector as shown above.
7. For good, reliable connections between the cable system and the strobe tube head in various weather and contamination conditions, it is strongly recommended that a dielectric grease be used on the connectors. It should be applied and into each terminal area where the connectors mate, before joining the two connectors together. We have found this procedure to be effective even under the most extreme of conditions. **Do Not Seal The Connectors Using Silicon Or RTV.**

PLITSTR133 REV. B 11/24/04

CK473

1. Enclosed you will find a kit containing 1 cable-side connector and 3 male pins.
2. Cut off the old connector from the cable on your vehicle, if present.
3. Strip 1½"-2" of the outer insulation off exposing the three inner wires.
4. These wires should be stripped each about ¼".



5. Secure each terminal by crimping the large tabs around the insulation and the si
6. After checking that your crimps are secure, insert the terminals into the correct holes in the connector as shown above.
7. For good, reliable connections between the cable system and the strobe tube head in various weather and contamination conditions, it is strongly recommended that a dielectric grease be used on the connectors. It should be applied and into each terminal area where the connectors mate, before joining the two connectors together. We have found this procedure to be effective even under the most extreme of conditions. **Do Not Seal The Connectors Using Silicon Or RTV.**

PLITSTR133 REV. B 11/24/04

CK473

1. Enclosed you will find a kit containing 1 cable-side connector and 3 male pins.
2. Cut off the old connector from the cable on your vehicle, if present.
3. Strip 1½"-2" of the outer insulation off exposing the three inner wires.
4. These wires should be stripped each about ¼".

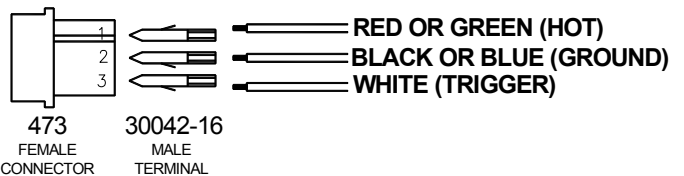

5. Secure each terminal by crimping the large tabs around the insulation and the si
6. After checking that your crimps are secure, insert the terminals into the correct h
7. For good, reliable connections between the cable system and the strobe tube head in various weather and contamination conditions, it is strongly recommended that a dielectric grease be used on the connectors. It should be applied and into each terminal area where the connectors mate, before joining the two connectors together. We have found this procedure to be effective even under the most extreme of conditions. **Do Not Seal The Connectors Using Silicon Or RTV.**

PLITSTR133 REV. B 11/24/04

CK473

1. Enclosed you will find a kit containing 1 cable-side connector and 3 male pins.
2. Cut off the old connector from the cable on your vehicle, if present.
3. Strip 1½"-2" of the outer insulation off exposing the three inner wires.
4. These wires should be stripped each about ¼".

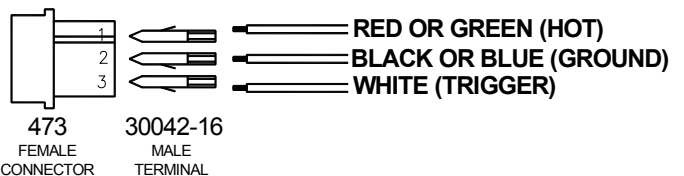

5. Secure each terminal by crimping the large tabs around the insulation and the si
6. After checking that your crimps are secure, insert the terminals into the correct h
7. For good, reliable connections between the cable system and the strobe tube head in various weather and contamination conditions, it is strongly recommended that a dielectric grease be used on the connectors. It should be applied and into each terminal area where the connectors mate, before joining the two connectors together. We have found this procedure to be effective even under the most extreme of conditions. **Do Not Seal The Connectors Using Silicon Or RTV.**

PLITSTR133 REV. B 11/24/04

LT1511 SWITCH (REAR VIEW)

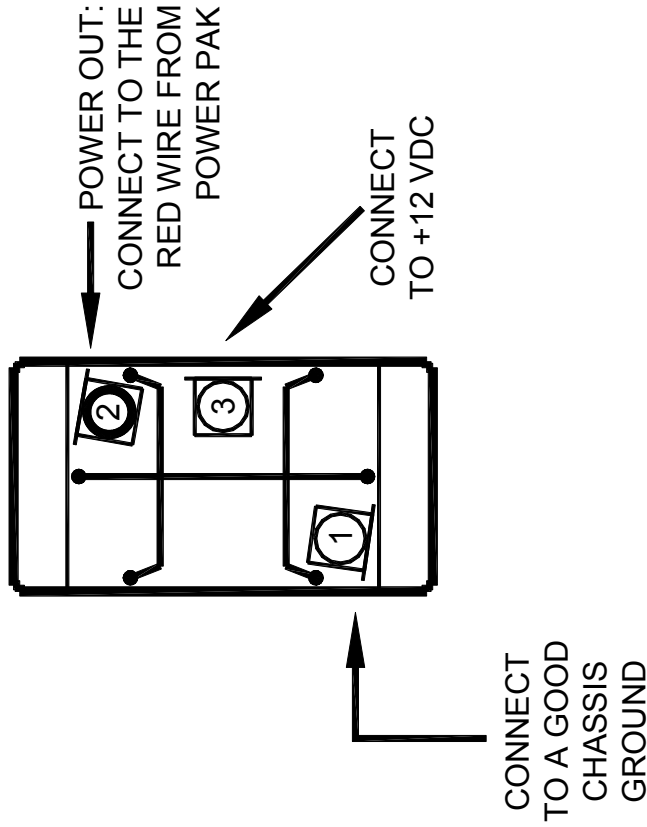

1. Connect Terminal 1 shown in the above picture to a Good Chassis Ground.
2. Connect Terminal 2 shown in the picture above to the Red wire which supplies power to your power pak.
3. Connect Terminal 3 to your +12 VDC power supply.
4. The above instructions will light the switch when it is turned on. If you would like to have the switch constantly lit swap the hook-ups to Terminal 2 and Terminal 3.

LT1511 SWITCH (REAR VIEW)

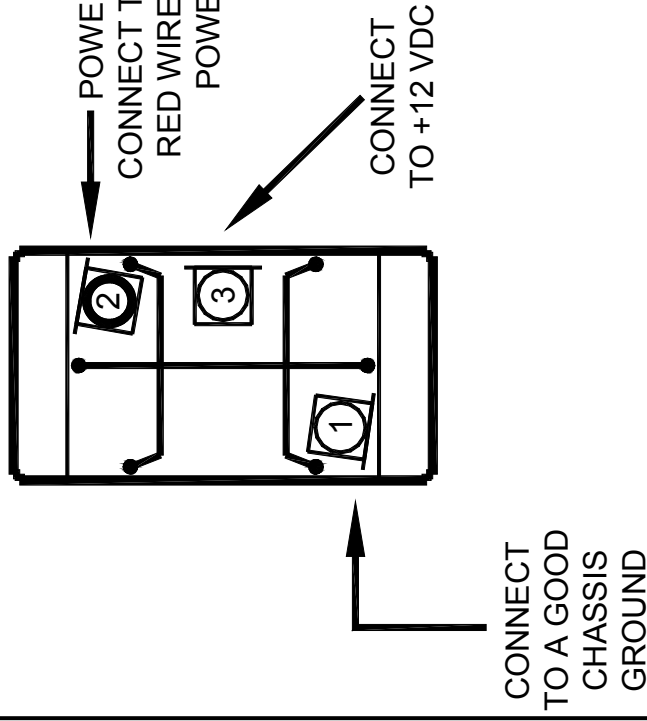

1. Connect Terminal 1 shown in the above picture to a Good Chassis Ground.
2. Connect Terminal 2 shown in the picture above to the Red wire which supplies power to your power pak.
3. Connect Terminal 3 to your +12 VDC power supply.
4. The above instructions will light the switch when it is turned on. If you would like to have the switch constantly lit swap the hook-ups to Terminal 2 and Terminal 3.

Star Headlight & Lantern Co., Inc.

455 Rochester Street Avon, NY 14414 Phone: 585-226-9787 FAX: 888-478-2797

STAR SAFETY SINCE 1889



455 Rochester Street Avon, NY 14414



Star Headlight & Lantern Co., Inc.

455 Rochester Street Avon, NY 14414 Phone: 585-226-9787 FAX: 888-478-2797

