

---

## INSTALLATION AND INSTRUCTION MANUAL

---

# DLXT

## Thinline Auxiliary LED Lights



**DLXT-121\*\*\***  
(12 VDC)

**DLXT-241\*\*\***  
(24 VDC)



**DLXT-124\*\*\***  
(12 VDC)

**DLXT-244\*\*\***  
(24 VDC)



PROUDLY MADE IN THE USA  
An ISO 9001:2008 Certified Company

---

## Star Headlight & Lantern Co., Inc.

455 Rochester Street Avon, NY 14414

Phone: 585-226-9787 FAX: 888-478-2797



[www.starheadlight.com](http://www.starheadlight.com)

PLIT424 REV. D 6/4/10



**IMPORTANT:** *Please read all of the following instructions before installing your new light. Failure to follow these safety precautions may result in damage to your light or vehicle and may result in serious injury or death to you and your passengers.*

The DLXT uses state -of-the-art Light Emitting Diode (LED) technology. This warning light is comprised of ultra-high intensity LEDs that are operated by a micro-controller to efficiently produce light output with lifetimes up to 100,000 hours.

#### NOTICE

Due to continuous product improvements, we must reserve the right to change any specifications and information, contained in this manual at any time without notice. Star Headlight & Lantern Co., Inc. makes no warranty of any kind with regard to this manual, including, but not limited to, the implied warranties of merchantability and fitness for a particular purpose. Star Headlight & Lantern Co., Inc. shall not be liable for errors contained herein or for incidental or consequential damages in connection with the furnishing, performance, or use of this manual.







**Important** This product is used to **warn** traffic. Improper use may result in vehicular collision, personal injury and/or death. Star Headlight & Lantern Co., Inc., and its subsidiaries shall not be held responsible for damages directly or indirectly caused by improper use of this product.

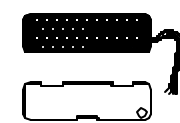
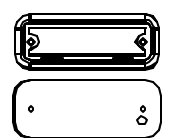
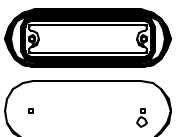
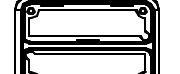

This light utilizes high-intensity LED Lamps. DO NOT stare directly into the light while it is on, as momentary blindness and/or permanent eye damage may occur.

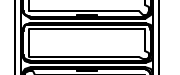
**Please Note:** These instructions are provided as a general guideline only. **Some vehicles may require special mounting, wiring, and/or weather-sealing. This is the sole responsibility of the installer.** Star Headlight & Lantern Co., Inc. assumes no responsibility for the integrity of the installation for this or any of its products.

## Parts

<p><b>LED Array</b> S8070-354-** (12VDC) S8070-354H** (24VDC)</p> <p><b>Foam Compression Gasket</b> P30047-119</p>	
<p><b>Single Rectangular 1X5 Bezel</b> P30019-132 (Black) P30019-132P (Chrome)</p> <p><b>Rectangular 1X5 Rubber Mounting Gasket</b> P30047-123</p>	
<p><b>Oval 1X5 Bezel</b> Black=P30019-133 Chrome=P30019-133P</p> <p><b>Oval 1X5 Rubber Mounting Gasket</b> P30047-124</p>	
<p><b>Double Rectangular Bezel</b> P30019-134 (Black) P30019-134P (Chrome)</p>	
<p><b>Double Rectangular Rubber Mounting Gasket</b> P30047-126</p>	
<p><b>Triple Rectangular Bezel</b> P30019-135 (Black) P30019-135P (Chrome)</p>	
<p><b>Triple Rectangular Rubber Mounting Gasket</b> P30047-127</p>	
<p><b>#6 x 3/4" Self Tapping Screws</b> P30052-33</p>	<p>QTY=2 per Single Bezel QTY=4 per Double or Triple Bezel</p> 
<p><b>#6-32 x 1/2" Machine Screws</b> P30052-7</p>	<p>QTY=2 per Single Bezel QTY=4 per Double or Triple Bezel</p> 
<p><b>Rubber Well Nuts</b> P30092-5</p>	<p>QTY=2 per Single Bezel QTY=4 per Double or Triple Bezel</p> 

## **Installation Notes**

Proper installation of the unit is essential for years of safe, reliable operation. Please read all instructions **before** installing the unit. Failure to follow these instructions can cause serious damage to the unit or vehicle and may void warranties.

- The installer must have a firm knowledge of basic electricity, vehicle electrical systems, and emergency equipment.
- If you need to drill any holes when installing this light, please take care to check that BOTH SIDES of your drilling surface are clear from obstructions, to ensure that you do not damage your vehicle and or pre-existing wiring.
- Choose a mounting location away from any air bag deployment areas.
- Controls should be placed within convenient reach of the driver.
- Use only soap and water when cleaning this product. Use of other chemicals may discolor the lens and/or housing, thus diminishing the output of the light. Lenses that have become discolored should be replaced immediately!
- DO NOT use a pressure washer to clean this light. Use of a pressure washer may damage the light and WILL VOID THE WARRANTY.

**Keep These Instructions** - Keep these instructions in the vehicle or other safe place for future reference. Advise the vehicle operator of the location.

### ***Before beginning the installation:***

- Determine where the light is to be mounted (on your mirror, on your dash, in your rear window, using a bracket, etc.).
- Check to see that there are no obstructions hindering the visibility of your light from the front, rear, or side of the vehicle (wherever applicable).
- Determine where you will mount the switch.
- Verify that you have a clear path between the light and switch for your wires to run.

## **Surface Mounting Instructions**

***Please Note:*** These instructions are provided as a general guideline only. ***Some vehicles may require special mounting, wiring, and/or weather-sealing. This is the sole responsibility of the installer.*** Star Headlight & Lantern Co., Inc. assumes no responsibility for the integrity of the installation for this or any of its products.

1. The DLXT is designed to be flush mounted to any flat surface using either two #6 x  $\frac{3}{4}$ " self tapping screws (P30052-33) or two #6-32 x  $\frac{1}{2}$ " machine screws (P30052-7) with two rubber well nuts (P30092-5). Four of each will be used for installations with the Double or Triple bezels. Use the self tapping screws for applications where the mounting surface is a minimum of .060" (1/16") thick and is composed of a material that will provide sufficient "bite" for the self tapping screw. Use the machine screws and well nuts if your surface is less than .060" thick and/or composed of a material insufficient for securing a self tapping screws.

***Please Note:*** The hardware provided should work for most applications. There may be certain applications where the enclosed hardware WILL NOT work and appropriate hardware should be obtained locally by the installer. *Proper mounting is the sole responsibility of the installer.* Star Headlight & Lantern Co., Inc. assumes no responsibility for the integrity of the installation for this or any of its products.

2. Select the location the light will be mounted. Verify that you have at least  $\frac{3}{4}$ " clearance on the backside of your mounting surface for the mounting screws and wires.

- Using the rubber gasket as a template, mark your two mounting holes and the one wire hole.  
**CAUTION!!: BE SURE BOTH SIDES OF THE MOUNTING SURFACE ARE CLEAR!!!**

*Rubber Mounting Gasket (P30047-123)*

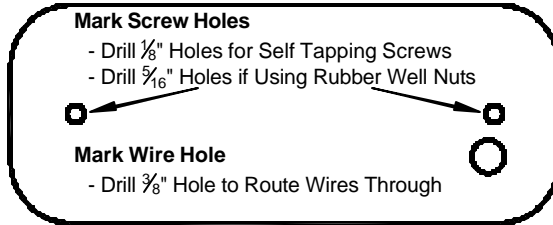

- Drill the mounting holes:
  - ▲ If you are using the self-tapping screws, drill a  $\frac{1}{8}$ " hole.
  - ▲ If you are using the well nuts, drill a  $\frac{5}{16}$ " hole.
- Then drill a  $\frac{3}{8}$ " hole to route your wires through. Be sure to file the edges of the wire hole so that it does not damage the insulation on any of the wires.

- Route the wires as shown to the right:

First through the Foam Compression Gasket, then through the Bezel, then through the Rubber Gasket, and finally through the mounting surface.

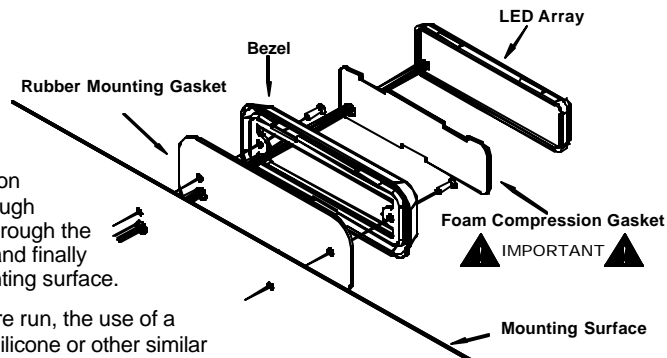

- Once the wires are run, the use of a small amount of silicone or other similar sealant (not included) is recommended to seal the wire hole and prevent your wires from becoming damaged.
- You can use the self-tapping screws only for metal mounting surfaces that are a minimum  $.060$ " ( $\frac{1}{16}$ " ) thick. Use the well nuts and machine screws for alternate mounting surfaces.

- If you are using the well nuts, push the enclosed rubber well nuts through the holes until the bottom side of the wider lip rests on the surface of the vehicle.

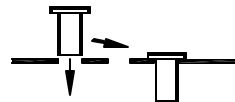

- Line the rubber mounting gasket up with the holes in your mounting surface or the well nuts and then place the bezel on top, lining its holes up as well. Insert the appropriate screws (self-tapping for metal surfaces and machine screws for the well nuts) through the bezel and rubber mounting gasket and carefully tighten the screws down. While tightening the screws down, check the gasket to ensure it is resting flat and that there are no gaps between the light and the mounting surface.

**CAUTION:** *Take extreme caution not to over tighten the screws!!! Over tightening of the screws can strip the holes and result in a faulty mount.*

- Once the bezel is firmly attached to the mounting surface, seat the foam compression gasket inside of it. Carefully feed any loose wire into the wire hole and press the LED head into the bezel.



**WARNING!** *It is the sole responsibility of the installer to ensure the warning light is secure. The manufacturer assumes no responsibility for the secure mounting of this light.*

## Wiring Instructions



When wiring your lights, YOU MUST take the following precautions to eliminate Electromagnetic Interference (EMI).

- The LED modules and the radio (or other sources of EMI) should be kept as far away from each other as possible.
- Separate the radio wires and the LED wires:
  - ▲ The radio antenna wire should make a right angle from the back of the radio and run down one side of the vehicle.
  - ▲ The LED wires should make a right angle out of the back of the switchbox and exit in the opposite direction of the antenna wire and/or radio power wires.
- Any excess wires should be cut short.
- The Ground wire, Power wire, and Synchronization wire should be bound tightly together as they run from light to light, through your switchbox, and finally to the battery.
- Do not ground each unit independently to the chassis. Run the ground for each unit as shown below in a "bus" like structure, to the negative terminal on the battery.



Power MUST be applied to all synchronized lights simultaneously. Excessive switch bounce or attempting to power the units up independently will result in erratic operation.

**Note:** The total distance between the two farthest units should be no more than 40 feet.

**BEFORE installing your lights and running your wires, please review the diagram below showing an example of how the wires should be run.**

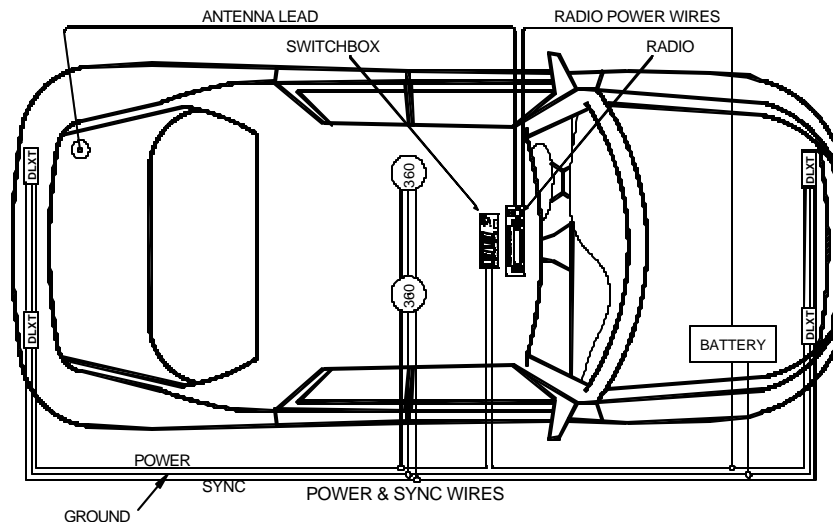

**(Wiring cont'd)**

There are five wires in the harness:

- Black:** (Ground) – Connect the black wire to the negative side of your battery.
- Red:** (Power) – Connect the red wire to your switch supplying +12VDC (DLXT-12 models) or +24VDC (DLXT-24 models).
- Green:** (Programming) – Use the green wire to program the flash pattern (explained on the following page).
- Green/White:** (Split/Single Mode) – The Green/White wire is used to set your light in either Split Mode (two halves flash alternately) or Single Mode (both halves illuminate simultaneously).  
*Split Mode=Connect to Power    Single Mode=Connect to Ground/Floating.*
- White:** (Synchro) – The white wire can be used to synchronize a total of six DLXT lights or other  lights together.

**Please Note:** When running your wires, the Black wire (battery-), the Red wire (battery +), and the White wire (synchronization) should be bound tightly together as they run from light to light, through your switchbox, and finally to the battery. **See the diagram on the previous page.**

1. Carefully route your wires to your switch panel (not included), and then to your battery as shown on the previous page. Use a minimum 22 AWG wire ensuring that you have made good solid connections that are isolated from one another.
2. Connect the black wire(s) to the negative terminal of the battery.
3. Connect the red wire(s) to power through a switch capable of handling at least 5 amps (user provided) and through a 5 amp fuse.
4. Connect the Green/White wire to power if you wish to run each light in Split Mode (two halves flash alternately)  
**or**  
Ground the Green/White wire if you wish to run each light in Single Mode (both halves illuminate simultaneously).
5. If you are only installing one unit, cut the White wire short and tape the end. If you will be synchronizing two of these units together, or synchronizing the light with other  lights, *leave the white wire disconnected for now*. Connect the white wires from both units together **ONLY AFTER PROGRAMMING** them for the same pattern (see Pattern Programming).

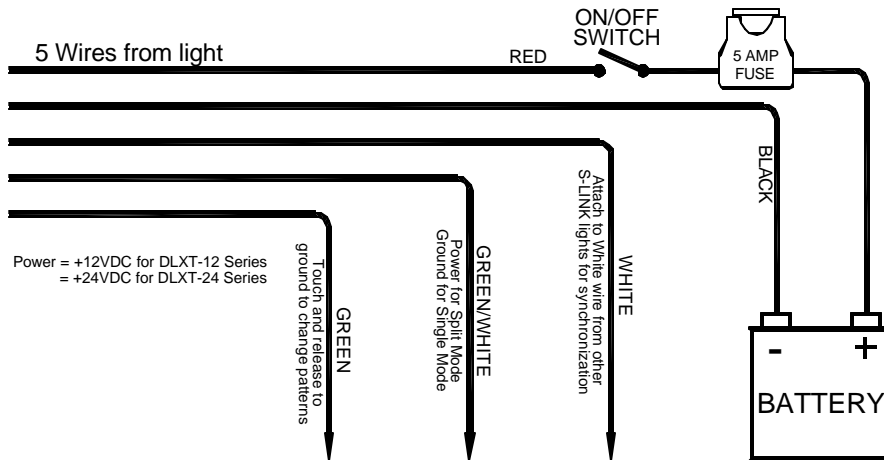

## Pattern Programming

1. If you are NOT synchronizing your light with any other compatible lights, tape the white wire off so that it does not come into contact with anything.
2. Determine whether you will be running your light in Split Mode or in Single Mode. In Split Mode, the two halves of the light will flash opposite one another (alternate). In Single Mode, the two halves of the light will flash together (simultaneous).



The Green/White wire will be connected with the Red wire (power) if you wish to run each light in Split Mode (two halves flash alternately)

**or**

The Green/White wire will be connected with the Black wire (Ground) if you wish to run each light in Single Mode (both halves illuminate simultaneously).

Flash Pattern #	Pattern Type	Side 1 Phase Or Single Mode	Side 2 Phase	<b>Pattern Description</b>	Additional Compatibility *
1	A	1	2	Fast Singleflash (1.9 CPS)	N/A
2	B			Flicker flash (1.7 CPS)	N/A
3	C			Post pop (1.4 CPS)	N/A
4	D			PSU -flicker (0.4 CPS)	N/A
5	E			Random (1.9 CPS) <b>(DEFAULT PATTERN)</b>	N/A
6	F			Quadflash (1.0 CPS)	1
7	G			Quadflash w/PostPop (1.0 CPS)	3
8	H			Singleflash (1.0 CPS)	6
9	I			Doubleflash (1.0 CPS)	7
10	J			Delta-Omega (0.3 CPS)	10
11	A	2	1	Fast Singleflash (1.9 CPS)	N/A
12	B			Flicker flash (1.7 CPS)	N/A
13	C			Post pop (1.4 CPS)	N/A
14	D			PSU -flicker (0.4 CPS)	N/A
15	E			Random (1.9 CPS)	N/A
16	F			Quadflash (1.0 CPS)	11
17	G			Quadflash w/PostPop (1.0 CPS)	13
18	H			Singleflash (1.0 CPS)	16
19	I			Doubleflash (1.0 CPS)	17
20	J			Delta-Omega (0.3 CPS)	20
21	F	N/A	N/A	Steady ( <i>see below</i> )	

\* - Compatible with these patterns from the 255HTCL, 9016 and LDF300

3. The **green wire** is used to program the desired flash pattern. After the Black, Red, and Green/White wires are connected, you may set the flash pattern.

Each light has 10 different Pattern Types you can cycle through (A-J) in two different Phases, and an additional "Steady Burn Mode".

If you are running in "Split Mode", the two halves will alternate the pattern back and forth. The chart above shows which side of the light flashes (or is "ON") during which Phase. Use this when synchronizing two lights that are in Split mode.

When synchronizing two lights that are in Single mode you will only use the '**Side 1 Phase or Single Mode**' column.

These lights are shipped programmed for Pattern 5 (Pattern Type E - Random). If you wish to select a different Pattern Type, proceed below:

- Touch and hold the green wire to ground until the light blinks once (approximately 3 seconds), then release it. This will reset the light to Pattern 1 (Pattern Type A/Phase 1).
- Touch the green wire to ground for approximately 1 second and release it to cycle through Patterns 1-20 shown above. After Pattern 20, the light will cycle back to Pattern 1.

**PLEASE NOTE:** The pattern cycle **does NOT** include the Steady Burn mode.

To access the Steady Burn pattern, proceed to the next page.

(Programming cont'd)

Programming Steady Burn Pattern in Split Mode:

- Power the light up (both Red and Green/White wire to power). Touch and hold the Green wire to Ground until the light blinks six times (approximately 18 seconds), then release it. One of the two halves will become steady, while the other flashes.
- To change the pattern on the flashing side, touch and release the Green wire to Ground.
- To flip-flop the steady side and the flashing sides, hold the Green wire to Ground until the light flashes 5 times (approximately 15 seconds) and then release it.

Programming Steady Burn Pattern in Single Mode:

To program a head in Single Mode for the Steady Burn pattern, power the light up (Red wire to power) with the Green/White wire attached with the Black wire to Ground. Touch the Green wire to Ground until the light blinks six times (approximately 18 seconds), then release it. The light should change to the Steady Burn pattern.

**Programming Shortcuts**

**Touch the Green**

**Wire to Ground For:**

3 seconds  
6 seconds  
9 seconds  
12 seconds  
15 seconds  
18 seconds

**Unit Blinks**

1 time  
2 times  
3 times  
4 times  
5 times  
6 times

**Jumps To**

Pattern 1  
Pattern 6  
Pattern 11  
Pattern 16  
Split/Steady Side Select ‡  
Steady Burn Pattern

‡ = **Only in Split Mode**

4. Once you have found the desired pattern, tape off or place a wrenut over the end of the green wire to prevent it from coming into contact with ground again. The light will "remember" the pattern when switched off and that pattern will be displayed the next time the light is switched on.

**If you ARE NOT synchronizing two or more units, you are finished programming.**

**Synchronization of Multiple Lights**



If you will be synchronizing two or more units together, leave the white wires disconnected until programming for each has been completed. Connect the white wires from the units together **ONLY AFTER PROGRAMMING** them all for the same Pattern Type (Phase MAY differ).

**You can synchronize up to six lights with  compatibility.**

1. If you are synchronizing two or more units, you must decide how you would like the lights to flash in conjunction with one another. Review the diagrams on the next page that show various flashing configurations.
2. Verify that the Green/White wire from each light is connected correctly so your heads are in the desired mode (Single or Split mode), as described on the previous page and the top of this page.
3. After programming the first light (as described on the previous page) program the second light based upon the desired output (shown on the following page). Keep in mind the following:
  - **ALL SYNCHRONIZED LIGHTS MUST HAVE THE SAME PATTERN TYPE (A-J) !!!**
  - For lights running in Single Mode, Patterns 1-10 are in Phase 1 and Patterns 11-20 are in Phase two.
  - For lights running in Split Mode, Patterns 1-10 flash side 1 in Phase 1 and side 2 in Phase 2. Patterns 11-20 flash side 1 in Phase 2, and side 2 in Phase 1.
  - Lights or sides set for the SAME phase flash together (simultaneous), lights with DIFFERENT phases flash opposite one another (alternate).
  - Use the Pattern Shortcuts listed above to simplify programming.

(Programming cont'd)

4. Once you have found the desired pattern on the second light, tape off or place a wirenut over the end of the green wire to prevent it from coming into contact with ground again.
5. Repeat Steps 1-4 above for each additional head you wish to synchronize.
6. **After** you have the correct patterns programmed in for **ALL** of the lights you wish to synchronize, turn all of the lights off and connect the white wires from all units together.
7. Power all of the lights up **at the exact same time** to verify they are flashing in the desired pattern.

### Single Mode

2 Complete flash cycles shown

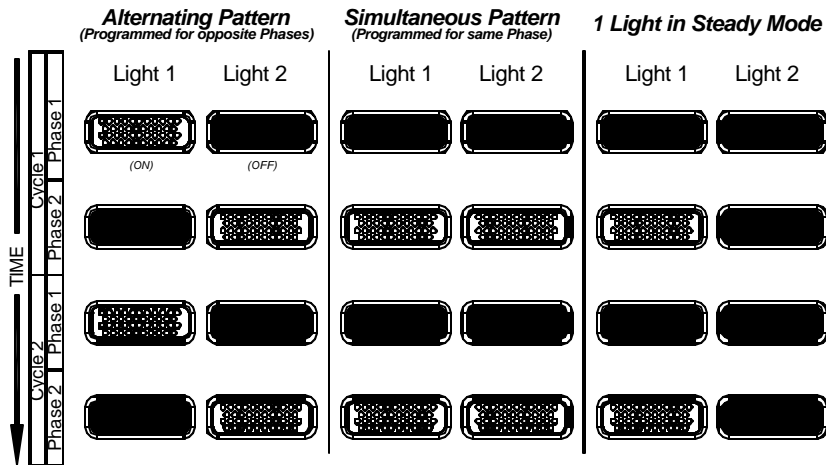

### Split Mode

2 Complete flash cycles shown

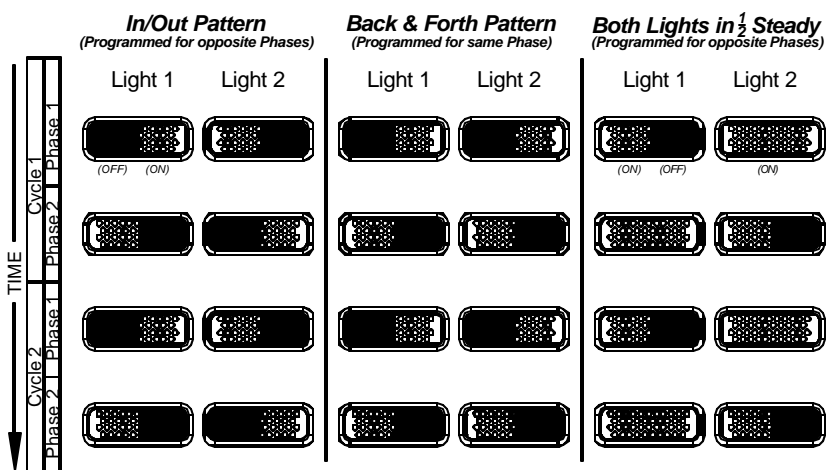

## ***Troubleshooting Guide***

The DLXT uses state-of-the-art Light Emitting Diode (LED) technology. This light is comprised of ultra-bright LEDs that are operated in a multiplexed mode to efficiently produce light output with lifetimes up to 100,000 hours. Under normal circumstances, you will not need to replace any LEDs in this light. If any of the LEDs in your light do fail, please contact Star Headlight for arrangements to have them repaired.

**NOTE:** Most failures can be traced to wiring and battery problems. Check "quick-connects" and wiring to insure that correct voltage/polarity is reaching the light.

Symptom	Possible Cause	Check
No Light	Power or polarity	A nominal +12VDC for DLXT-12 series or +24VDC for DLXT-24 series should be reaching the red wire Is power hooked up backwards? Positive ground vehicle? (Unit designed for negative ground vehicles)
	Inline fuse blown	Is an external fuse or circuit breaker used?
	Bad ground	Are the negative leads connected to a good ground?
	White wire shorted	White wire should only be connected to other white wires. +12VDC for DLXT-12 series or +24VDC for DLXT-24 series will prevent the light from flashing
	Green wire shorted	Green wire should remain unconnected. If grounded, light will cease to function.
	Shorts	Do wires run thru bare metal holes that have damaged them?  Are the wires pinched or broken anywhere?
LED's appear dim	Low battery voltage	Measure: Voltage below 12V for DLXT-12 series or +24VDC for DLXT-24 series, LED output will be reduced.
	Power wires are too small/long	Measure: Voltage below 12V for DLXT-12 series or +24VDC for DLXT-24 series at the unit, LED output will be reduced.
Erratic operation	Bad routing of wires	Do wires run thru bare metal holes that have damaged them?  Are the power or control wires close to:  Strobe power supplies, tubes, cables, police/two-way radios or alternator?
		Try running with the car and all other accessories off

## ***Optional Mounting***

There are also seven (7) optional mounting brackets for units with single rectangular bezels, if you do not wish to surface mount them. A diagram of these optional mounts can be found on the following page.

<b>274-DLXT-U</b>	<b>Universal "L"-Bracket</b>
<b>274-DLXT-W</b>	<b>Side (Vertical) Window Bracket</b>
<b>274-DLXT-T</b>	<b>Trunk Bracket</b>
<b>274-DLXT-45</b>	<b>45° Angled Bracket</b>
<b>274-DLXT-2X1</b>	<b>"L"-Bracket For Mounting Two Stacked Lights</b>
<b>274-DLXT-1X2</b>	<b>"L"-Bracket For Mounting Two Side-by-Side Lights</b>
<b>274-DLXT-RL</b>	<b>Rear License Plate Bracket for Mounting Two Lights</b>

Oval lights can also be mounted using an optional rubber grommet (**P/N 527**) that is designed to fit into the standard oval light housings found on most commercial vehicles.

## Optional Mounts

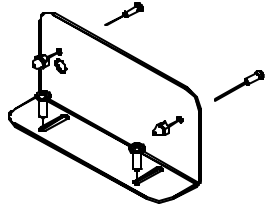

**274-DLXT-U**  
Universal "L"-Bracket

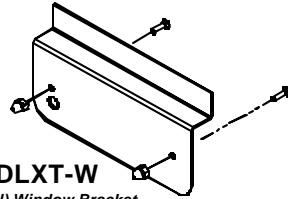

**274-DLXT-W**  
Side (Vertical) Window Bracket

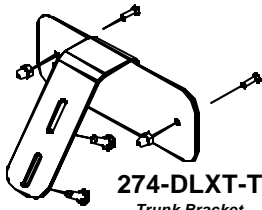

**274-DLXT-T**  
Trunk Bracket

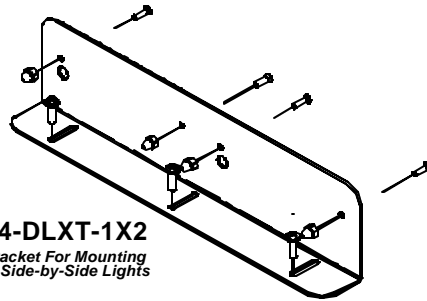

**274-DLXT-1X2**  
L-Bracket For Mounting  
Two Side-by-Side Lights

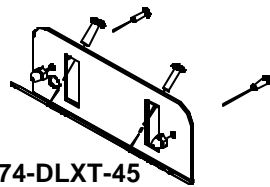

**274-DLXT-45**  
45° Angled Bracket

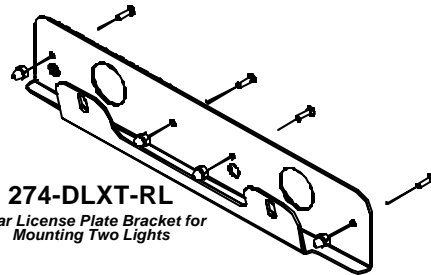

**274-DLXT-RL**  
Rear License Plate Bracket for  
Mounting Two Lights

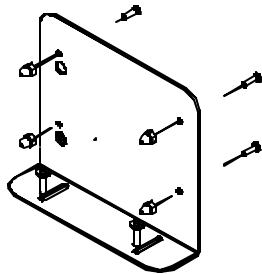

**274-DLXT-2X1**  
L-Bracket For Mounting Two  
Stacked Lights



**527**  
Oval Rubber Grommet

## LED FIVE YEAR LIMITED WARRANTY

The manufacturer warrants this LED light against factory defects in material and workmanship for five years after the date of purchase. The owner will be responsible for returning to the Service Center any defective item(s) with the transportation costs prepaid. The manufacturer will, without charge, repair or replace *at its option*, products, or part(s), which its inspection determines to be defective. Repaired or replacement item(s) will be returned to the purchaser with transportation costs prepaid from the service point. A copy of the purchaser's receipt must be returned with the defective item(s) in order to qualify for the warranty coverage. Exclusions from this warranty include, but are not limited to, domes, and/or the finish. This warranty shall not apply to any light, which has been altered, such that in the manufacturer's judgment, the performance or reliability has been affected, or if any damage has resulted from abnormal use or service.

There are no warranties expressed or implied (including any warranty of merchantability or fitness), which extend this warranty period. **The loss of use of the product, loss of time, inconvenience, commercial loss or consequential damages, including costs of any labor, are not covered.** The manufacturer reserves the right to change the design of the product without assuming any obligation to modify any product previously manufactured.

This warranty gives you specific legal rights. You might also have additional rights that may vary from state to state. Some states do not allow limitations on how long an implied warranty lasts. Some states do not allow the exclusion or limitation of incidental or consequential damages. Therefore, the above limitation(s) or exclusion(s) may not apply to you.

If you have any questions concerning this or any other product, please contact our **Customer Service Department** at (585) 226-9787.

If a product must be returned for any reason, please contact our Customer Service Department to obtain a Returned Material Authorization number (RMA #) before you ship the product back.

Please write the RMA # clearly on the package near the mailing label.



PROUDLY MADE IN THE USA  
An ISO 9001:2008 Certified Company

## Star Headlight & Lantern Co., Inc.

455 Rochester Street Avon, NY 14414

Phone: 585-226-9787 FAX: 888-478-2797



[www.starheadlight.com](http://www.starheadlight.com)





**PROUDLY MADE IN THE USA**  
*An ISO 9001:2008 Certified Company*