

INSTALLATION AND INSTRUCTION MANUAL

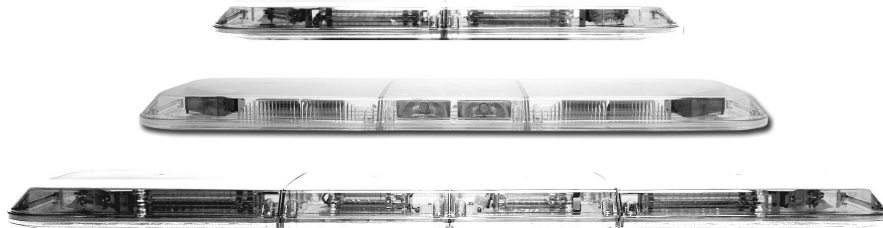

STAR RAZOR LIGHTBARS



PROUDLY MADE IN THE USA
An ISO 9001:2008 Certified Company

Star Headlight & Lantern Co., Inc.

455 Rochester Street Avon, NY 14414

Phone: 585-226-9787 FAX: 888-478-2797



www.starheadlight.com

PLITSTR341 REV F 8/4/11



When mounting your lightbar, please be sure to keep any radio frequency sensitive equipment at least 20" from the bar and power cable(s). This is especially critical in lightbars utilizing strobes. Our strobe power supplies have been designed to limit RFI emissions, but certain very sensitive equipment may still be affected. Symptoms may include, but are not limited to, sporadic operation and degraded performance. Star Headlight & Lantern Co., Inc. cannot assume any responsibility for any radio frequency induced malfunction or damage to any radios, sirens, lightbars, or any other equipment mounted within 20" of a strobe lightbar. Any antennae mounted in the proximity of the lightbar may cause your radio to suffer the aforementioned results.



PLEASE NOTE: THE DIRECT MOUNT IS THE STANDARD MOUNT INCLUDED WITH THE LIGHTBAR. THE HOOK MOUNTS MUST BE USED ON ALL POLICE AND/OR OTHER EMERGENCY VEHICLES!!! THE HOOK MOUNTS ARE SOLD SEPARATELY. THEY ARE NOT INCLUDED WITH EACH LIGHTBAR. THEY MUST BE ORDERED SEPARATELY. SEE THE ACCOMPANYING HOOK MOUNT MANUAL FOR A COMPLETE LIST OF AVAILABLE MOUNTS AND KNOWN VEHICLE APPLICATIONS.



It is the sole responsibility of the owner to ensure the lightbar is mounted securely. Check your light every time you enter the vehicle to ensure that it is mounted securely. The manufacturer assumes no responsibility for the secure mounting of this light.



WARNING!

These lightbars contain one or more of the following light sources: Strobe Lights, Halogen Lamps, and/or High Intensity LED Lamps. **DO NOT** stare directly into any of these light sources as temporary blindness and/or permanent eye damage may occur.

Please Note: These instructions are provided as a general guideline only. Specific mounting, wiring, and/or weather-sealing may be necessary and are the sole responsibility of the installer. Star Headlight & Lantern Co., Inc. assumes no responsibility for the integrity of the installation for this or any of its products.

Table of Contents

WARNINGS	i
QUICK-INSTALL WIRING GUIDE	1-2
MOUNTING INSTRUCTIONS	3
(For Mounting see <i>Mounting Bracket</i> Manual)	
WIRING INSTRUCTIONS	3-6
Direct Wiring Guide	3-4
Electrical Connections	5
Wire Functions	6
PATTERN PROGRAMMING	7-10
Strobe Pack Flash Patterns	7
LED Flash Patterns	8-10
PARTS	11-12
SWITCHES	13
TROUBLESHOOTING	14-16
WARRANTY	17
SERVICE	17

NOTICE

Due to continuous product improvements, we must reserve the right to change any specifications and information, contained in this manual at any time without notice. Star Headlight & Lantern Co., Inc. makes no warranty of any kind with regard to this manual, including, but not limited to, the implied warranties of merchantability and fitness for a particular purpose. Star Headlight & Lantern Co., Inc. shall not be liable for errors contained herein or for incidental or consequential damages in connection with the furnishing, performance, or use of this manual.

QUICK-INSTALL WIRING GUIDE

Please Note: If your lightbar has an LED or incandescent traffic director in it, there will also be a separate bundled 9-conductor cable specifically for that function.

Wire Harness for Bars With LED STT Lights P271-TOWBAR Layout 2

Wire Harness for Bars with Incandescent STT Lights P271-TOWBAR Layout 1

Wire Harness for Bars Without Stop/Tail/Turn Lights P271-RAZOR

Terminal Block	Terminal	Color	AWG	Function
A	1	Blue	18	Driver side Alley
	2	White w/Blue	18	Intersection Clearing Lights
	3	White w/Yellow	18	Front Corner
	4	Orange w/Yellow	18	Front Outboard
	5	Brown w/Yellow	22	Front Inboard and Ends
	6	Red	14	Power
	7	Red w/Green	22	Pattern Select
	8	Purple	22	High/Low Power (Ground for Low)
	9	Green w/Yellow	18	Front Takedowns
	10	Red w/Black	18	AUX
	11	White w/Brown	18	Front Pursuit
	12	Green w/Red	18	Rear Center or TD Warn
	13	Brown w/Red	22	Rear Inboard or TD Left
14	Orange w/Red	22	Rear Outboard or TD Right	
B	1	White w/Red	18	Rear Corner (rear ICL)
	2	Yellow w/Black	18	Cruise
	3	White w/Black	18	Alley w/Flash
	4	Gray	18	Passenger Alley
CONNECTED TO BASE		Black	10	Ground (Battery Negative)
		Bare	18	Shield/Drain (Battery Negative)
Terminal Block	Terminal	Color	AWG	Function
A	1	Light Blue	16	Driver Side Alley Light
	2	Orange	14	Rotators
	3			
	4	Yellow	16	Left Stop Light
	5	Green	16	Right Stop Light
	6	White/Orange	14	Work Lights
	7	Brown	18	Tail Lights/I.D. Lights
	8			
	9	Red	14	Strobe Power
	10	Red/White	14	Power for Optional Components
	11	Red/Green	22	Strobe Pattern Select
	12	Black/Green	22	Strobe Head Select 1
	13	White/Green	22	Strobe Head Select 2
	14	Gray	16	Passenger Side Alley Light
CONNECTED TO BASE		Black	10	Ground (Battery Negative)
		Bare	18	Shield/Drain (Battery Negative)
Terminal Block	Terminal	Color	AWG	Function
A	1	OPEN		
	2	OPEN		
	3	OPEN		
	4	Blue		OPEN or Driver Alley or Steady Burn Alley
	5	Orange	16	Front LEDs
	6	White w/Orange	14	Rear Work Lights
	7	Red	14	Strobe Power
	8	Red w/White	14	Rear LEDs
	9	Red w/Green	22	Pattern Select
	10	Black w/Green	22	Strobe Control 1 or OPEN
	11	White w/Green	22	Strobe Control 2 or OPEN
	12	Gray	16	OPEN or Passenger Alley
B	1	Yellow	16	Left (Driver) Turn Signal
	2	Diode		Red 6" Wire
	3	OPEN		
	4	Green	16	Right (Passenger) Turn Signal
	5	Diode		Red 6" Wire
	6	OPEN		
	7	Brown	18	Tail Lights
	8	Diode		Red 6" Wire/Power
CONNECTED TO BASE		BLACK	10	Ground (Battery Negative)
		BARE	18	Shield/Drain (Battery Negative)

Typical 46" Lightbar Layouts

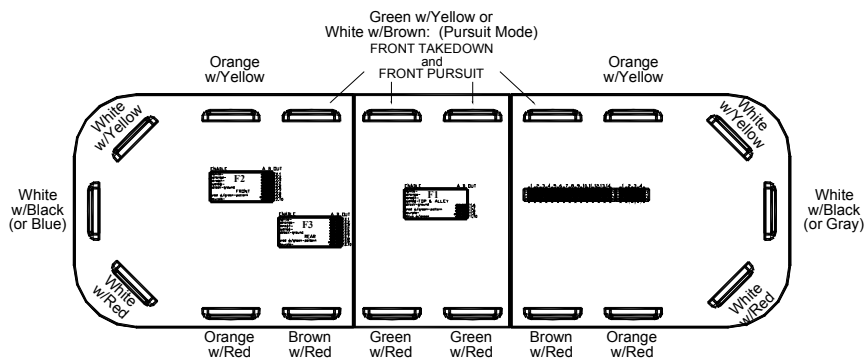
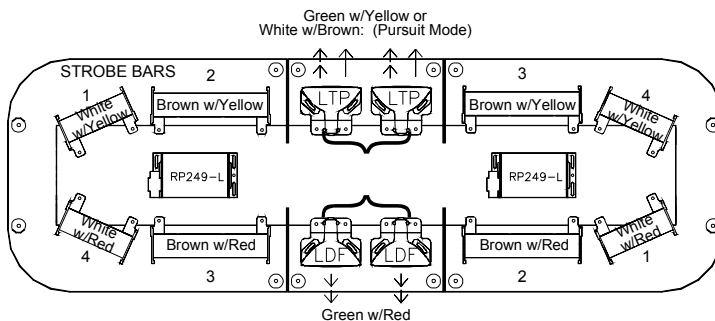
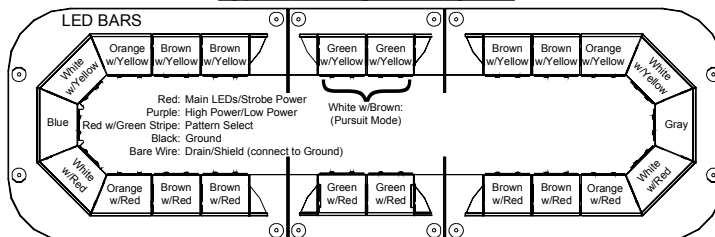

Mounting Instructions

Please review the separate Mounting Bracket manual that is also enclosed with your bar for mounting instructions.

Wiring Instructions

All standard lightbar models are designed for 12VDC negative ground vehicles only. Reverse polarity will cause serious damage to the lightbar and/or vehicle. Contact the automotive dealer if there are any doubts about the polarity of your vehicle.

Direct Wiring Guide

PLEASE NOTE: If you are using the existing 15-foot cable supplied with the lightbar, you may skip to the Electrical Connections section on page 4.

If the wire supplied is too short. Star recommends direct wiring to the terminal block on the inside of the lightbar, rather than making connections to the end of the wire that is supplied. This lightbar is designed so that no wire connectors are needed and only a few common tools are necessary in order to do this. Direct wiring allows the wire connections to the lightbar to be made in a clean and dry environment, avoiding any problems that may arise due to weathering on external connections. There is also an increase in voltage loss with the addition of each connection. Wiring directly inside the lightbar reduces the number of connections. However, making connections to the wires already provided is an acceptable alternative, as long as these connections are good electrical connections and are resistant from weathering effects. For direct wiring into the lightbar, follow the instructions listed below.

1. Determine the number of wires that you will need to run. The standard harness used in these lightbars has 16 conductors, plus a drain wire and a foil shield. Your lightbar may not need all of the wires. Please note which functions your bar has, then review the *Wire Harness Usage Table* on page 1 to determine which wires you will need to connect. The drain wire and foil shield in our standard harness are optional (but recommended) and are only necessary if you are experiencing RFI problems.
2. Locate the end of the lightbar with the wire harness attached to it. The black terminal blocks that you will be making your wire connections at, should also be located at the same end.
3. Remove the dome lens at this end of the lightbar:
 - Step A:** Loosen the 4 screws securing each dome.
 - Step B:** Lift the dome off of the base exposing the interior components, or the metal plate covering the interior components (some models). If you have no metal plate, skip to Step 4.
 - Step C:** If your lightbar has a metal plate covering the components, remove all of the screws holding the plate on. The number of screws may vary depending upon the layout of your lightbar.
 - Step D:** Lift the plate off the lightbar exposing the interior components.
4. When all work is completed, reinstall the plate and dome, taking care that the gasket is properly aligned.

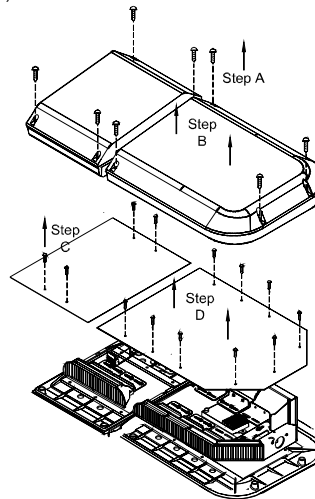

(Direct Wiring Guide CONT'D)

5. All of the wires coming from outside of the lightbar are terminated on the same side of the terminal block and the wires leading to the internal components terminate on the opposite side of the terminal block. Loosen the screws on the terminal block and remove **only those wires that exit the lightbar through the hole in the base**. There may be "dead" wires from the harness connected to the terminal block inside your lightbar, but there will be no wires connected to the terminal across from them. These are extra wires in the harness that are not used. Replacing these wires in your new harness is not necessary.

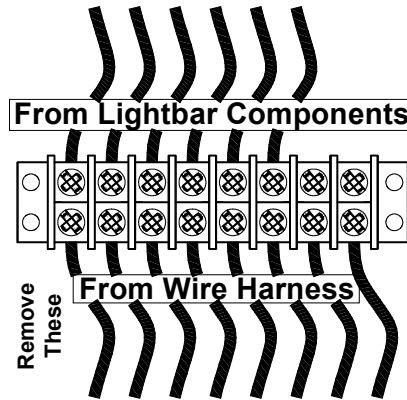

6. Run the new external wires up through the wire bushing into the base and into the terminal block(s). The function of each of the colored wires in the original wiring harness is listed in the *Wire Harness Usage Table* on page 1. There should also be a label next to the terminal block indicating which color wire should be connected to each terminal.
7. Strip each wire 1/4". Connect the external wires to the proper poles of the terminal block by inserting the stripped portion of the wire under the rising clamp screw and tightening down the screw. No wire terminals are needed for connecting wires to this terminal block.

Be sure to check that no strands of wire are loose and shorting to the adjacent terminal or to the base of the lightbar.

The correct wire size and color listed in the table on page 1 corresponds directly with the wiring of the lightbar. All switches used should be rated for at least 125% of their rated load.

8. Once your new wire harness has been connected to the lightbar, you may continue to the *Electrical Connections* section.



Electrical Connections

All standard lightbar models are designed for 12VDC negative ground vehicles only. Reverse polarity will cause serious damage to the lightbar and/or vehicle. Contact the automotive dealer if there are any doubts about the polarity of your vehicle.



RF INTERFERENCE

Please take the following steps to help eliminate any Radio Frequency Interference (RFI) with your two-way radio.

- **DO NOT** run the power wire for the lightbar along same path as any antenna wires.
 - **DO NOT** run the power wire for the lightbar along same path as any radio power wires.
 - **DO NOT** tap power for the lightbar off of the radio power wires.
 - **DO NOT** mount the lightbar within 20" of any antennae. Sometimes mounting the lightbar or antenna over by just one foot can make a large difference in the interference.
 - Ensure the black wire from the lightbar has a good connection to the **negative side of the battery.**
-
- For all standard Razor lightbars, 15 feet of 16-conductor cable (plus a drain wire and a foil shield) is supplied with the bar. All wires are color coded and sized at the correct gauge. If this length is not sufficient, it is recommended that the wire harness be completely replaced with the only connections to be made directly at the terminal block inside the lightbar. This will reduce the number of wire connections and help prevent any weathering problems on these connections. Refer to the *Direct Wiring Guide* on pages 2-3 for further instructions on this.
 - **CAUTION: All wires and switches should be rated for at least 125% of their maximum current load.** In addition, all wires connected to the positive terminal of the battery should be fused at the battery for 125% of their rated load. The load can be calculated by adding all lamp wattages and dividing by 13. (Load <Amps> = Total Watts / 13 volts) **Do not use** 1/4" diameter glass fuses, as they are not suitable for continuous duty above 20 amps. A table of recommended wire colors and wire sizes is provided on page 1. If you are unsure of the current draw, please contact our Customer Service Department.
 - **TESTING THE LIGHTBAR BEFORE IT IS PROPERLY FUSED & INSTALLED WILL VOID THE WARRANTY!!**
 - The black ground wire should be connected to the negative terminal of your vehicle's battery. This wire should be at least #10 AWG wire and be as short as possible in order to minimize the voltage loss in this wire and reduce any chance of overheating.
 - Since many of the lightbars we build have custom components, occasionally wire colors may slightly vary. If you are unsure of the function of a particular wire, you may test the function by grounding the black wire and applying +12VDC to the wire in question. Be sure to use a 20-amp fuse when testing.

Wire Functions

PLEASE NOTE: There are three different harnesses that could be installed on your lightbar. Please review the *Quick-Install Wiring Guide* on page 1 for proper connection of your wires. Your harness will contain all of the colored wires, the drain wire, and the foil shield, but most applications will not use every wire. The “dead” wires in the harness will be connected to the terminal block inside your lightbar, but there will be no wires connected to the terminal across from them. These “dead” wires can be used for additional components that may be added at some point in the future, or they may be used to separately switch components that are currently wired together.

Black: (GROUND) - The black wire is the ground wire and MUST be connected on EVERY lightbar.

Red: (Power/+12VDC) - The red wire provides the main power to the LED flashers and/or strobe packs. Connect the red wire directly to continuous +12VDC through a high-current fuse.

Please Note: When the red wire is connected to +12VDC the pack will draw a small current (50 mA). If your vehicle will be sitting for extended periods of time (i.e. more than a few days), it is recommended the red wire be routed through a switch or ignition switched relay.

Bare Wire: (Drain/GROUND) - This wire will help eliminate RFI. We recommend that it be connected to ground.

Purple: (High/Low Power) - The purple wire is optional and can be used to switch LED applications to low power. Connect the purple wire to ground to operate the bar under low power.

Red w/Green: (Pattern Select/Touch and Release to +12VDC) - The red w/green stripe wire is used to select the flash pattern of your LEDs or strobes. **It will normally be left unconnected.** (For more detailed instructions, see **Pattern Programming** on pages 8-10).

 **Please note:** If you have a lightbar with a strobe pack or LED flasher, the Red w/Green Stripe wire is only used when programming the flash pattern. This wire MUST NOT be connected to continuous +12VDC!!! Once the pattern has been selected, tape the end of this wire off. (See pages 8-10)

All Other Colors: The remaining wires are typically On/Off controls for the lights shown in the corresponding *Quick-Install Wiring Guide* on the page 1. Most applications will not use every color wire.

Connect the wires that your lightbar utilizes to +12VDC through your switches (not included). The “dead” wires (not needed) will be connected to the terminal block inside your lightbar, but there will be no wires connected to the terminal across from them. These wires do not need to be connected at the other end of the harness.

Pattern Programming

- Lightbars with LEDs or strobes can be programmed with the user's choice of flash pattern.
 - If you have both strobes and LEDs in your lightbar, **programming of the strobe pack(s) and LED flasher(s) must be done separately.**
 - If you have multiple strobe packs or multiple LED flashers, all of the strobe packs can be programmed together and all of the LED flashers can be programmed together or each strobe pack or LED flasher can also be programmed separately, if you desire different patterns for each.
1. To program the flash pattern turn **only** the strobe pack(s) or LED flasher on that you wish to program.
 2. Briefly touch the red w/green stripe wire to +12VDC and release it. Continue to briefly touch and release this wire to +12VDC until you find the pattern desired. The pattern lists for the strobe packs or various LED flashers can be found below and on the following three pages.
 3. Once you have the pattern you like, turn the pack or flasher off. The pack or flasher will remember the pattern next time it is activated.
 4. Repeat steps 1-3 for each additional strobe pack or LED flasher you wish to program.
 5. Once your programming is complete, tape the end of the red w/green stripe wire so that it does not come into contact with +12VDC.

Strobe Pack Flash Patterns

<u>Pattern</u>	<u>Warning Pattern Style</u>
1	Alternating Five-Flash (<i>default</i>)
2	Pseudo-Random
3	Alternating Singleflash
4	Alternating Doubleflash
5	Alternating Quadflash

The strobe packs are defaulted for Five-Flash mode. You can scroll through pseudo-random, singleflash, doubleflash, quadflash, and back to five-flash by touching and releasing the red w/green stripe wire to +12VDC.

Please note: If you have only the corner strobes activated (white w/yellow wire or white w/red wire), heads 1 and 4 will alternate (see the center lightbar layout diagram on page 2). If you have only the front or rear strobes activated (brown w/yellow or brown w/red) then heads 2 and 3 will alternate. If you activate the corners AND the fronts or rears at the same time, heads 1 and 4 will flash together, opposite of 2 and 3.

Automatic Power Up Head Check

Each 4-outlet power pack comes with a safety feature which checks for proper operation of each individual strobe head each time you turn on the strobe pack. This feature works by quickly flashing each head once separately and determining if any of the heads did not flash. If two heads normally flash together, and one fails and does not flash during the start up test, the strobe pack will automatically reduce the output power to that particular side so that the "other" remaining head(s) isn't over powered. The power to that side will be reduced until the strobe pack is turned off and on again and the faulty head tests good.

The 4-outlet strobe pack will check all four heads each time the pack is turned on EVEN if the head select feature is being used and only two heads are to be activated. After checking all four heads, the pack will begin flashing normally. It takes approximately 0.250 sec. to check all four heads.

Note: If you replace the non-working head, it is necessary to cycle power to the pack before that head and the one that flashes with it will start flashing again at full power. (*You should never replace a defective head with the pack activated!!*)

LED Flash Patterns

Front and Rear DLX6 and Batwing LED Patterns (LDF375-1 Flasher)

Pattern	Warning Pattern Style
1	Pursuit Mode (1 flash/3 sec default)
2	Alternating Slow Single (1-5 vs 6-10) (Title 13 Approved)
3	Alternate Pursuit Mode
4	Alternating Quad Flash (1-5 vs 6-10)
5	Alternating Triple (1,2,6,7,8 vs 3,4,5,9,10)
6	Alternating Quint (1,2,6,7,8 vs 3,4,5,9,10)
7	Simultaneous Slow Single (All Modules) (Title 13 Approved)
8	Simultaneous Fast Single (All Modules)
9	Simultaneous Triple Flash (All Modules)
10	Simultaneous Quad Flash (All Modules)
11	Simultaneous Quint Flash (All Modules)
12	Simultaneous Fast Triple Flash (All Modules)
13	Simultaneous Fast Quint Flash (All Modules)
14	In/Out Single (1,2,9,10 vs 3-8)
15	In/Out Triple (1,2,9,10 vs 3-8)
16	In/Out Quint (1,2,9,10 vs 3-8)
17	In/Out Single (1,2,3,8,9,10 vs 4-7)
18	In/Out Triple (1,2,3,8,9,10 vs 4-7) (2 flashes/6 sec default)
19	In/Out Quint (1,2,3,8,9,10 vs 4-7)
20	1-5 Steady; 6-10 Single Flash (Title 13 Approved)
21	1-5 Steady; 6-10 Slow Single Flash (Title 13 Approved)
22	6-10 Steady; 1-5 Single Flash (Title 13 Approved)
23	6-10 Steady; 1-5 Slow Single Flash (Title 13 Approved)
24	Sequential Back And Forth (3 flashes/9 sec default)
25	Sequential In/Out
26	Burst All w/ Alternating Burst
27	Alternating Burst w/ Simultaneous Double Then Quint
28	Simultaneous Burst w/ Alternating Double Then Quint
29	Hyper-Random
30	Pre-Pop Triple Flash
31	Alternating Pre-Pop Triple Flash
32	Demo (Cycle Through Patterns 1-4,6-9,13-20,25-29)

Please Note: At any time during the programming sequence, you can reset the flash pattern back to any of the default patterns (Pattern 1, 18, or 24) by holding the red w/green Pattern Select wire to +12VDC until the heads flash the specified number of times, then releasing it.

Each LED flasher has 20 output terminals (10 pairs). The two terminals in each pair are electrically connected and will flash at the same time. The numbers in parenthesis in the list above indicate which output pairs flash together vs. the pairs they flash opposite of.

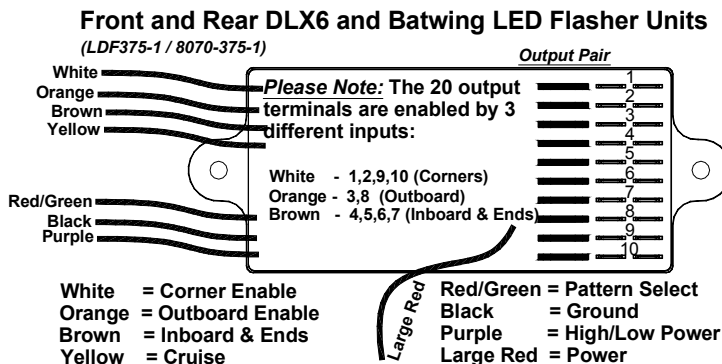

(LED Pattern Programming CONTD)

Takedown or Alley Light DLX6 and Batwing LED Patterns
(LDF375-2 Flasher)

- Pattern Warning Pattern Style**
- 1 Pursuit Mode (1 flash/3 sec default)
 - 2 Alternating Slow Single (1,3 vs 2,4) (Title 13 Approved)
 - 3 Alternate Pursuit Mode
 - 4 Alternating Quad Flash (1,3 vs 2,4)
 - 5 Alternating Triple (1,3 vs 2,4)
 - 6 Alternating Quint (1,3 vs 2,4)
 - 7 Simultaneous Slow Single (All Modules) (Title 13 Approved)
 - 8 Simultaneous Fast Single (All Modules)
 - 9 Simultaneous Triple Flash (All Modules)
 - 10 Simultaneous Quad Flash (All Modules)
 - 11 Simultaneous Quint Flash (All Modules)
 - 12 Simultaneous Fast Triple Flash (All Modules)
 - 13 Simultaneous Fast Quint Flash (All Modules)
 - 14 In/Out Single (1,3 vs 2,4)
 - 15 In/Out Triple (1,3 vs 2,4)
 - 16 In/Out Quint (1,3 vs 2,4)
 - 17 Simultaneous Double Flash, Post-Pop (2 flashes/6 sec default)
 - 18 Simultaneous Triple Flash, Post-Pop
 - 19 Simultaneous Quint Flash, Post-Pop
 - 20 Alternating Double Flash, Post-Pop (1,3 vs 2,4)
 - 21 Alternating Triple Flash, Post-Pop (1,3 vs 2,4)
 - 22 Alternating Quint Flash, Post-Pop (1,3 vs 2,4)
 - 23 Alternating Pre-Pop Quint Flash (1,3 vs 2,4)
 - 24 Sequential Back And Forth (3 flashes/9 sec default)
 - 25 Sequential In/Out
 - 26 Burst All w/ Alternating Burst
 - 27 Alternating Burst w/ Simultaneous Double Then Quint
 - 28 Simultaneous Burst w/ Alternating Double Then Quint
 - 29 Hyper-Random
 - 30 Demo (Cycle Through Patterns 1-4,6-9,13-20,25-29)

The numbers in parenthesis in the list above indicate which output pairs flash together vs. the pairs they flash opposite from.

Please Note: Please Note: At any time during the programming sequence, you can reset the flash pattern back to any of the default patterns (Pattern 1, 18, or 24) by holding the red w/green Pattern Select wire to +12VDC until the heads flash the specified number of times, then release it.

Takedown (Pursuit) and Alley LED Flasher Units
(LDF375-2 / 8070-375-2)

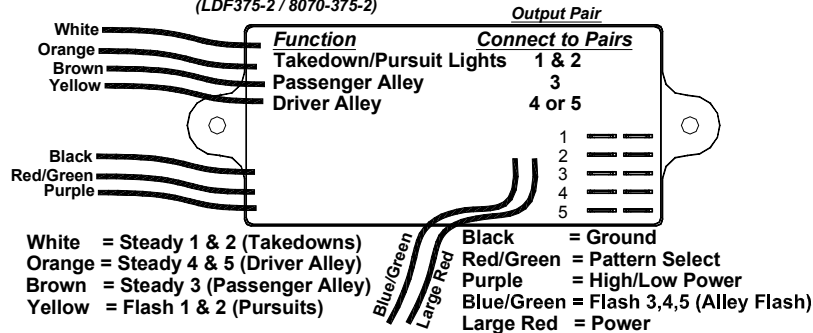

(LED Pattern Programming CONTD)

Patterns for All LEDs Excluding DLX6 and Batwing
(LDF398 Flasher)







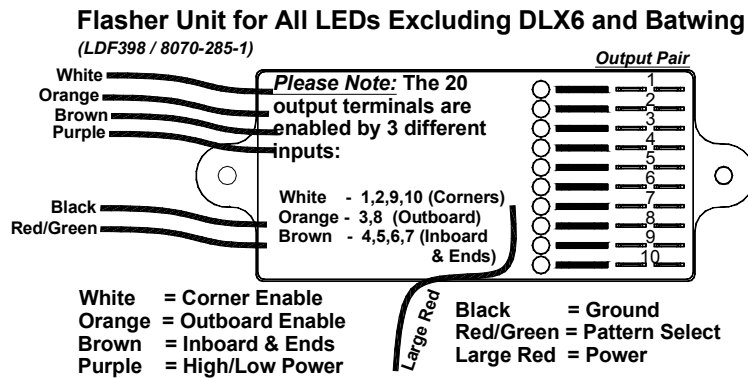



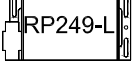

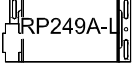



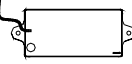



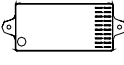

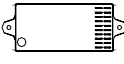
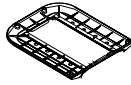



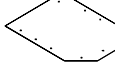

Pattern	Warning Pattern Style
1	Pursuit Mode (Default)
2	Alternating Slow Single (1-5 vs 6-10) (Title 13 Approved)
3	Alternate Pursuit Mode
4	Alternating Quad Flash (1-5 vs 6-10)
5	Alternating Triple (1,2,6,7,8 vs 3,4,5,9,10)
6	Alternating Quint (1,2,6,7,8 vs 3,4,5,9,10)
7	Simultaneous Slow Single (All Modules) (Title 13 Approved)
8	Simultaneous Fast Single (All Modules)
9	Simultaneous Triple Flash (All Modules)
10	Simultaneous Quad Flash (All Modules)
11	Simultaneous Quint Flash (All Modules)
12	Simultaneous Fast Triple Flash (All Modules)
13	Simultaneous Fast Quint Flash (All Modules)
14	In/Out Single (1,2,9,10 vs 3-8)
15	In/Out Triple (1,2,9,10 vs 3-8)
16	In/Out Quint (1,2,9,10 vs 3-8)
17	In/Out Single (1,2,3,8,9,10 vs 4-7)
18	In/Out Triple (1,2,3,8,9,10 vs 4-7)
19	In/Out Quint (1,2,3,8,9,10 vs 4-7)
20	1-5 Steady; 6-10 Single Flash (Title 13 Approved)
21	1-5 Steady; 6-10 Slow Single Flash (Title 13 Approved)
22	6-10 Steady; 1-5 Single Flash (Title 13 Approved)
23	6-10 Steady; 1-5 Slow Single Flash (Title 13 Approved)
24	Sequential Back And Forth
25	Sequential In/Out
26	Burst All w/ Alternating Burst
27	Alternating Burst w/ Simultaneous Double Then Quint
28	Simultaneous Burst w/ Alternating Double Then Quint
29	Hyper-Random
30	Demo (Cycle Through Patterns 1-4,6-9,13-20,25-29)

Each LED flasher has 20 output terminals (10 pairs). The two terminals in each pair are electrically connected and will flash at the same time. The numbers in the list above, in the parenthesis, indicate which output pairs flash together vs. the pairs they flash opposite of.

Please Note: At any time during the programming sequence, you can reset the flash pattern back to the default mode (Pattern 1 – Pursuit) by holding the red w/green Pattern Select wire to +12VDC for 5 seconds, then releasing it.





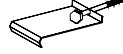









































STAR RAZOR **Parts**

- | | | | |
|---|---|---|--|
|  | LST129-4
4.5" LINEAR STROBE TUBE |  | RP249-L
4-HEAD REMOTE STROBE PAK |
|  | LST129-7
7" LINEAR STROBE TUBE |  | RP249A-L
2-HEAD REMOTE STROBE PAK |
|  | 2073-H27
27-WATT HALOGEN BULB
(TAKEDOWN/PURSUIT, FLASHER,
ICL, WORKLIGHT) |  | TD77-2
TRAFFIC DIRECTOR CONTROL BOX |
|  | 2073-1157
STT BULB |  | LDC-TD
LED CONVERTER CIRCUIT FOR TD |
|  | 2073-FTEFG
BULB FOR 220-50 ALLEY LIGHT |  | FM3662
2.9 FPS HALOGEN FLASHER |
|  | 520-21-*
UPPER END DOME |  | LDF398
8-OUTPUT LED FLASHER
(20 OUTPUT TERMINALS) |
|  | 520-22-*
UPPER CENTER DOME |  | LDF375-1
8-OUTPUT LED FLASHER w/CRUISE
FOR VERSASTAR HEADS
(20 OUTPUT TERMINALS) |
|  | 220-21L-*
LOWER RAZOR END DOME |  | LDF375-2
8-OUTPUT LED FLASHER FOR
ALLEYS & TDP VERSASTAR HEADS
(20 OUTPUT TERMINALS) |
|  | 220-22L-*
LOWER RAZOR CENTER DOME |  | LDF288-ICL
8-OUTPUT LED FLASHER FOR
ALLEYS & TDP VERSASTAR HEADS
(20 OUTPUT TERMINALS) |
|  | 220-ETC
METAL END TOP COVER |  | LDF369
2-OUTPUT LED FLASHER FOR ALL LED H
EXCEPT M-TECH & VERSASTAR (8 OUTP) |
|  | 220-CTC
CENTER END TOP COVER |  | LSF-EC-*
LINEAR STROBE ENDCAP |
|  | 820-100LL
Filter for Halogen/Incandescent Light |  | 220-ECL
M-TECH LEFT ENDCAP W/LENS |
|  | LSF4.5-5-*
4.5" LINEAR STROBE FILTER |  | 220-ECR
M-Tech Right Endcap w/Lens |
|  | LSF7-5-*
7" LINEAR STROBE FILTER |  | 30053-33
TOP DOME SCREWS |
|  | 30047-61
DOME GASKETING (1 FOOT) |  | 820-39-PB
BLACK NYLON DIRECT MOUNT KIT |
| | |  | HOOK MOUNTS
THESE ARE PICTURED IN THE HOOK
MOUNT MANUAL AND WORK IN
CONJUNCTION WITH THE 820-39-PB |

* = COLOR (White, Black, Clear, or Gray)

Please note that these items are not drawn to scale. Many have been enlarged to show more detail.

(Parts CONT'D)

- | | | | |
|---|---|---|--|
|  | 220-D1-*
M-TECH LED LIGHTHEAD |  | 220-D1V-*
M-TECH VALUE LED LIGHTHEAD |
|  | 220-D1AL-*
M-TECH LED LIGHTHEAD
w/LEFT ANGLE REFLECTOR |  | 220-D1ALV-*
M-TECH VALUE LED LIGHTHEAD
w/LEFT ANGLE REFLECTOR |
|  | 220-D1AR-*
M-TECH LED LIGHTHEAD
w/RIGHT ANGLE REFLECTOR |  | 220-D1ARV-*
M-TECH VALUE LED LIGHTHEAD
w/RIGHT ANGLE REFLECTOR |
|  | 220-D1A-*
M-TECH LED LIGHTHEAD
w/DUAL ANGLE REFLECTOR |  | 220-D1AV-*
M-TECH VALUE LED LIGHTHEAD
w/DUAL ANGLE REFLECTOR |
|  | 220-D1LEC-*
M-TECH LED LIGHTHEAD
w/LEFT ENDCAP |  | 220-D1LECV-*
M-TECH VALUE LED LIGHTHEAD
w/LEFT ENDCAP |
|  | 220-D1REC-*
M-TECH LED LIGHTHEAD
w/RIGHT ENDCAP |  | 220-D1RECV-*
M-TECH VALUE LED LIGHTHEAD
w/RIGHT ENDCAP |
|  | 220-D1EC-*
M-TECH LED LIGHTHEAD
w/BOTH ENDCAPS |  | 220-D1ECV-*
M-TECH VALUE LED LIGHTHEAD
w/BOTH ENDCAPS |
|  | 220-D3-*
M-TECH LED 3-LIGHTHEAD
END ASSEMBLY |  | 220-D3V-*
M-TECH VALUE LED 3-LIGHTHEAD
END ASSEMBLY |
|  | 220-D2-*
M-TECH LED 2-LIGHTHEAD
END ASSEMBLY |  | 220-D2V-*
M-TECH VALUE LED 2-LIGHTHEAD
END ASSEMBLY |
|  | 220-D2-1*
M-TECH LED 2-LIGHTHEAD END
ASSEMBLY w/ENDCAPS |  | 220-D2V-1*
M-TECH VALUE LED 2-LIGHTHEAD
END ASSEMBLY w/ENDCAPS |
|  | 220-D1TDK
M-TECH LED 6-LIGHTHEAD TRAFFIC DIRECTOR |  | 220-D1VTDK
M-TECH VALUE LED 6-LIGHTHEAD TRAFFIC DIRECTOR |
|  | LDL121-TDK
STARBURST LED 6-LIGHTHEAD TRAFFIC DIRECTOR |  | SH3924 (SH3924-1 when angled)
4.5" LINEAR STROBE HEAD |
|  | S520-DLX6TDK6A
DLX6 TRAFFIC DIRECTOR KIT |  | SH3927
7" LINEAR STROBE HEAD |
|  | S520-BWTDK6A
BATWING TRAFFIC DIRECTOR KIT |  | 220-14LDH
DIRECTIONAL HALOGEN
(TAKEDOWN/PURSUIT, FLASHER, ICL.
WORKLIGHT) (Less Bulb) |
|  | 220-DLXTC
DLXT LED HEAD |  | 220-14STT
STOP/TURN/TAIL LIGHT |
|  | 220-DLX6-1*
DLX6 INNER LED WITH BRACKET |  | 220-50
ALLEY LIGHT |
|  | S520-DLX6-1*
DLX6 INNER LED |  | 220-50-1
ALLEY LIGHT TO FIT
WITH M-TECH 220-D2 |
|  | 220-DLX6-3*
DLX6 END OR CORNER LED WITH BRACKET |  | S520-DLX6-HK
DLX6 LED ALLEY LIGHT |
|  | S520-DLX6-3*
DLX6 END OR CORNER LED |  | S520-DLX6-2A
DLX6 T.D. LED |
|  | 220-DLX6-4*
DLX6 OUTER LED WITH BRACKET |  | S520-308-6*
BATWING T.D. LED |
|  | S520-DLX6-4*
DLX6 OUTER LED |  | LDL121-*
STARBURST LED ARRAY w/LONG
BRACKET FOR FRONT & REAR
(222 OPTICS) |
|  | S520-308-4*
BATWING LED |  | 220-51LED-*
DIRECTIONAL LED FLOOD/TAKEDOWN |
|  | 220-308-4*
BATWING LED WITH BRACKET | | |

*=COLOR

Please note that these items are not drawn to scale.

Switches and Switchboxes

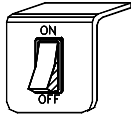

SP3860-1

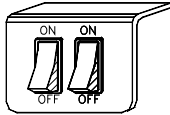

SP3860-2

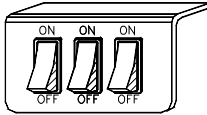

SP3860-3

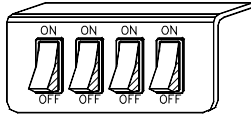

SP3860-4

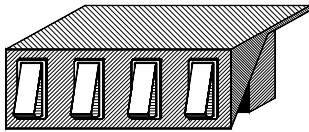

SP1515

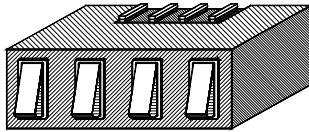

SB1515

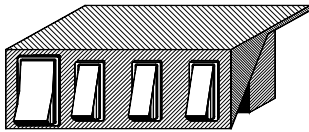

SP3015

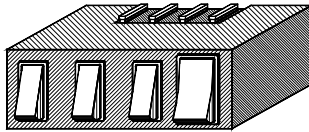

SB3015

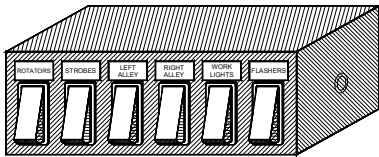

SB4020

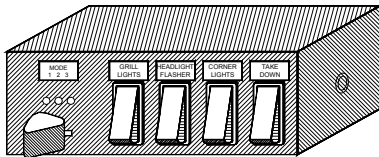

SB4040

Troubleshooting



CAUTION: High voltages exist in electronic strobe lights. Before attempting service on any strobe light, be sure to disconnect the power for at least five minutes to allow the capacitor to discharge. Failure to heed this warning may result in severe electrical shock and/or injury.

Please Note: Most strobe and rotating beacon failures can be traced to wiring and battery problems. Before attempting any service on the circuit itself, please be sure to check all connections and wiring to ensure the correct voltage and/or polarity is reaching your light or remote head.

*If a light on your bar fails to work, please refer to this section to help solve your problem. If you still cannot resolve your problem, please contact our **Customer Service Department** at 585-226-9787.*

The chart below contains some basic guidelines for troubleshooting any problems you may experience with your bar. The section following the chart will explain in further detail how to perform some of the troubleshooting tasks.

<u>Symptom:</u>	<u>Possible Solutions</u>
One single LED light is Out	LED Head needs to be replaced
One LED head does not flash	Check wiring between LED head and flasher unit Check LED head Check that +12VDC is applied to control line for that head
Multiple LED heads not flashing	Check power to terminal block Check that the bar is properly grounded Check power from terminal block to LED flasher unit Check that the LED flasher unit is grounded properly Check that +12VDC is applied to control line for those heads Check that the red w/green stripe pattern select wire is not connected to +12VDC
One flashing light out	Check bulb Check power wire from flasher unit to bulb Check that the bulb is grounded
Multiple flashing lights out	Check power to terminal block Check that the bar is properly grounded Check power from terminal block to flasher unit Check that the flasher unit is grounded properly
One remote strobe head out	Check the strobe head Check the cable from the remote pack to the strobe head
Multiple strobe heads out	Check power to terminal block Check power to strobe pack Power Outlet (PWR) Check power to strobe pack Control Outlets (CTRL) Check that the pack is properly grounded Check that the red w/green stripe pattern select wire is not connected to +12VDC

Determining if the bar is properly grounded:

1. While the bar is turned on, using a test meter, measure the voltage from the base of the bar itself to the negative post of the battery or a good chassis ground if the battery can't be easily reached. You may need to scrape away a bit of anodizing or paint in order to ensure a good connection with the probe of your test meter.
2. If the difference shown is greater than .25 volts, then your ground is not sufficient.
3. If the ground is insufficient, locate the ground wire connection in your lightbar by removing the dome over the section where the wires enter the bar. Please follow the appropriate dome removal instructions listed earlier in this manual when removing this dome. The ground wire is the large (10AWG) black wire attached to the inside of the lightbar base with a ring terminal. Check the integrity of the connection of the ground wire to both the lightbar base and at the other end to a good chassis ground.
4. While inspecting the ground wire connections you should also check that the wire itself is not damaged. Carefully inspect the wire along its entire length, paying special attention to those areas where the wire passes through any holes that may have sharp edges, which can damage the wire, and the areas where the wire makes any sharp bends.

**Checking the power to the terminal block
(Determining if the proper voltage is reaching your bar):**

1. Locate the terminal block in your lightbar by removing the dome over the section where the wires enter the bar. Please follow the appropriate dome removal instructions listed earlier in this manual when removing this dome. After entering the bar, the wires will be connected to the terminal block with a number of small Phillips head screws.
2. With the bar turned on, use a test meter to test the voltage at the terminal block. A nominal 12.5 volts should be present. Low voltage can cause erratic flashing in strobe heads or even complete failure of the heads. A minimum of 10.5 volts should be present for the pack to operate properly. Low voltage in strobe lights, flashing lights, or LEDs can result in lowered intensity or even complete failure.
3. Be sure to test each wire that comes into the terminal block for proper voltage.
4. Carefully inspect each wire in the terminal block. Check that the ends of the wires have not frayed and shorted against one another or against the base. This may cause lights to operate inadvertently or may result in the failure of lights.

Checking one non-working strobe or LED head:

If a problem exists in only one head, a strobe tube or LED head may have burned out, or there may be an open electrical connection in the wiring harness or strobe head.

1. Check connections at and between the strobe pack and the faulty strobe head or between the flasher unit and LED head, including all wiring.
2. Disconnect both the faulty head and a working head.
3. Check the faulty head by connecting it into the side you just unplugged the working head from. If the faulty head still does not work, then the head is bad and will need to be replaced.
4. If the head that was not flashing works when connected to the other side, the problem probably lies in the power pack or flasher unit. Verify this by plugging the other head (the original working head you just unplugged) into the side that previously had the non-working head.

Checking multiple non-working strobe or LED heads:

If two or more of the heads connected to one of the packs are not flashing, follow these steps to determine the problem:

1. Check the power to the terminal block as explained on the previous page.
2. Check that the bar is grounded properly as explained on the previous page.
3. Check all fuses, including those at the battery, at the switch panel, in the dash, and on the pack (if applicable). Remove these fuses, and check them to confirm they have not blown. Replace any blown fuses with only fuses of identical values. Replacing the fuse with the wrong rating may damage your pack and/or vehicle, and will void your warranty.
4. Check that the proper voltage is reaching the pack or flasher unit with the vehicle turned off and while the bar is running. For strobe packs, measure the voltage across the red wire (pin 1) and the black or blue wire (pin 2) of the **PWR** connector on the power pack. Push the probes of the test meter down into the connector at the wire entry points to contact the terminals for the measurement. Note this reading. A nominal 12.5 volts should be present. Low voltage to the pack can cause erratic flashing in the heads or even complete failure of the heads. A minimum of 10.5 volts should be present for the pack to operate properly. If you do not have proper voltage present skip to step 8. If your pack is receiving sufficient voltage then continue to step 5.
5. Check that the proper voltage is reaching the Black wire and White wire of the **CTRL** plug on your strobe pack with the vehicle turned off and while the bar is running. Measure the voltage across the Black wire (pin 2) and a good chassis ground. Push the probes of the test meter down into the connector at the wire entry points to contact the terminals for the measurement. Note this reading. Also check the voltage on the White wire. A nominal 12.5 volts should be present. A minimum of 10.5 volts should be present for the pack to operate properly. If you do not have proper voltage present, skip to step 8. If your pack is receiving sufficient voltage then continue to step 6.
6. Check that there is NO VOLTAGE on the Red w/Green Stripe wire (Pattern Select wire) of the **CTRL** plug on your strobe pack. Measure the voltage across the Red w/Green stripe wire (pin 1) and a good chassis ground. Push the probes of the test meter down into the connector at the wire entry points to contact the terminals for the measurement. If there is voltage being applied to this wire, it will prevent the strobe pack from flashing.
7. If the leads in one of the heads have shorted out, the output voltage of the other heads may be held down as well. To test for this, unplug all of the heads and plug them in individually, one at a time. If your problem is a result of a shorted head, then the other heads should function properly if the faulty head is no longer connected. Note: A burned out strobe tube does not cause a short and will not affect the operation of the remaining heads. If the problem is not with a shorted head and if proper voltage is reaching the pack, the problem is most likely internal to the pack. Call Star to obtain an R.G.A. number to return the pack for service.
8. If sufficient voltage is not reaching the pack perform the following tests: With the vehicle turned off and while the pack is running, measure the battery voltage *at the battery*. A nominal 12.5 volts should exist. Note this voltage. If this voltage is below 10.0 volts the pack will not function properly and the problem is with the battery. This reading should not be more than 1-1.25 volts higher than the reading in the 4th step. If there is an excessive difference then continue on to the next step.
9. With the vehicle not running and the lightbar on, measure the voltage in the red wire by taking a reading from the positive side of the battery to pin 1 of your switch. If this reading exceeds 0.25 volts then there is a poor connection between the switch and the battery in the red wire and it should be checked.
10. If you still have not located the problem, troubleshoot the connections between the good chassis ground and pin 2 (black wire) of the **PWR** connector on the power pack, while the lightbar is running. If this reading exceeds 0.25 volts then there is a poor connection between the switch and the ground in the black wire and it should be checked.
11. This same procedure can be used to check the wires between the terminal block and the pack. Place one probe on the terminal at the terminal block and the other probe into the terminal with the corresponding wire color in the connector on the pack. Once again if any of the readings exceed 0.25 volts then you should check those wires and their connections.

ONE YEAR LIMITED WARRANTY LED FIVE YEAR LIMITED WARRANTY

The manufacturer warrants each new product, under normal use, against factory defects in material and workmanship for **one year** after the date of purchase. The manufacturer warrants the **LED components** in this light against factory defects in material and workmanship for **five years** after the date of purchase. The owner will be responsible for returning to the Service Center any defective item(s) with the transportation costs prepaid. The manufacturer will, without charge, **repair or replace at its option**, products, or part(s), which its inspection determines to be defective. Repaired or replacement item(s) will be returned to the purchaser with transportation costs prepaid from the service point. A copy of the purchaser's receipt must be returned with the defective item(s) in order to qualify for the warranty coverage. If a copy of the receipt is not provided, the warranty period shall cover five years from the date of manufacture.

Exclusions from this warranty include, but are not limited to, bulbs, strobe tubes, domes, and/or the finish. This warranty shall not apply to any light, which has been altered, such that in the manufacturer's judgment, the performance or reliability has been affected, or if any damage has resulted from abnormal use or service. This warranty does not apply to defect or damage occurring as a result of disaster, accident, abuse, misuse, lightning, power surges, or failure to follow instructions in any enclosed manuals. Any damage or defects occurring as a result of any unauthorized service or repairs by unauthorized persons shall be excluded from this warranty.

There are no warranties expressed or implied (including any warranty of merchantability or fitness), which extend these warranty period. **The loss of use of the product, loss of time, inconvenience, commercial loss or consequential damages, including costs of any labor, are not covered.** The manufacturer reserves the right to change the design of the product without assuming any obligation to modify any product previously manufactured.

This warranty gives you specific legal rights. You might also have additional rights that may vary from state to state. Some states do not allow limitations on how long an implied warranty lasts. Some states do not allow the exclusion or limitation of incidental or consequential damages. Therefore, the above limitation(s) or exclusion(s) may not apply to you.

If you have any questions concerning this or any other Star product,
please contact our **Customer Service Department** at (585) 226-9787.

If a product must be returned for any reason, please contact
our Customer Service Department to obtain a
Returned Materials Authorization number (RMA #) before you ship the product to Star.
Please write the RMA # clearly on the package near the mailing label.



PROUDLY MADE IN THE USA
An ISO 9001:2008 Certified Company

Star Headlight & Lantern Co., Inc.

455 Rochester Street Avon, NY 14414

Phone: 585-226-9787 FAX: 888-478-2797



www.starheadlight.com