

# INSTALLATION INSTRUCTIONS FOR MODELS 200CF, 200CFD, 200CFQ, and 200JF

- IMPORTANT:** Please read all of the following instructions before installing your new strobe light. This instruction sheet applies only to the Star models listed above.
- CAUTION:** All of our DC powered warning lights are polarity sensitive. These lights are polarity protected *only if the appropriate fuse* is used. All wires connected to the positive terminal of the battery should be fused at the battery for their rated load. **Testing the light before this fuse is properly installed will void the warranty on the light.**
- Your new Star warning light comes complete with a foam mounting gasket, three mounting screws, three lock washers, and three rubber well nuts.
- Remove the foam gasket from the shipping box. Each gasket comes furnished with three outer holes. (NOTE: You might have to stretch the gasket to find the location of the three holes).
- Place the gasket in the exact position the light is to be mounted. Using the gasket as a template, mark the three outer holes and a hole in the center for your wires on the mounting surface. Take care to ensure that the gasket does not move while you are marking each of the four holes.
- Remove the gasket and drill a 3/8" hole in the four marked locations. **CAUTION:** Take care not to drill through the headliner of the vehicle below.
- Push the enclosed rubber well nuts through the three outer holes until the bottom side of the wider lip rests on the surface of the vehicle.
- Place the light on the surface of the vehicle, routing the wires through the center hole in the gasket and then the center hole in the mounting surface. Align the three holes in the flange of the light with the three outer holes in the gasket and the three rubber well nuts in the mounting surface. Install the three screws through the flange and gasket, into the well nuts. Tighten until snug.
- The black wire is the ground lead and should be connected to a good chassis ground.
- For model 200CFD or 200CFQ skip to Step 11. **For the 200CF and 200JF** proceed as follows:  
Connect the red wire to the positive side of the power through a single-pole, two position switch (available from Star part #SP3860-1) and a 5 Amp fuse. Skip the remaining step.
- For the 200CFD or 200CFQ**  
**Low power only operation:** Leave the purple wire unconnected and place a wirenut on the end.  
**High power only operation:** Connect the purple wire to ground with the black wire.  
**HIGH/LOW operation:** Refer to the wiring diagram on the reverse side of this sheet for proper connections using a two-switch switch-panel available from Star. (Ask for Part # SP3860-2H).

**Please Note:** These instructions are provided as a general guideline only. Specific mounting, wiring, and/or weather-sealing may be necessary and are the sole responsibility of the installer. Star Headlight & Lantern Co., Inc. assumes no responsibility for the integrity of the installation for this or any of its products.



**CAUTION:** High voltages exist in electronic strobe lights. Before attempting service on any strobe light, be sure to disconnect the power for at least five minutes to allow the capacitor to discharge. Failure to heed this warning may result in severe electrical shock and/or injury.

**Please Note:** Most strobe and rotating beacon failures can be traced to wiring and battery problems. Before attempting any service on the circuit itself, please be sure to check all connections and wiring to ensure the correct voltage and/or polarity is reaching your light or remote head.

If you have any questions concerning this or any other Star product, please contact our Customer Service Department at (585) 226-9787.

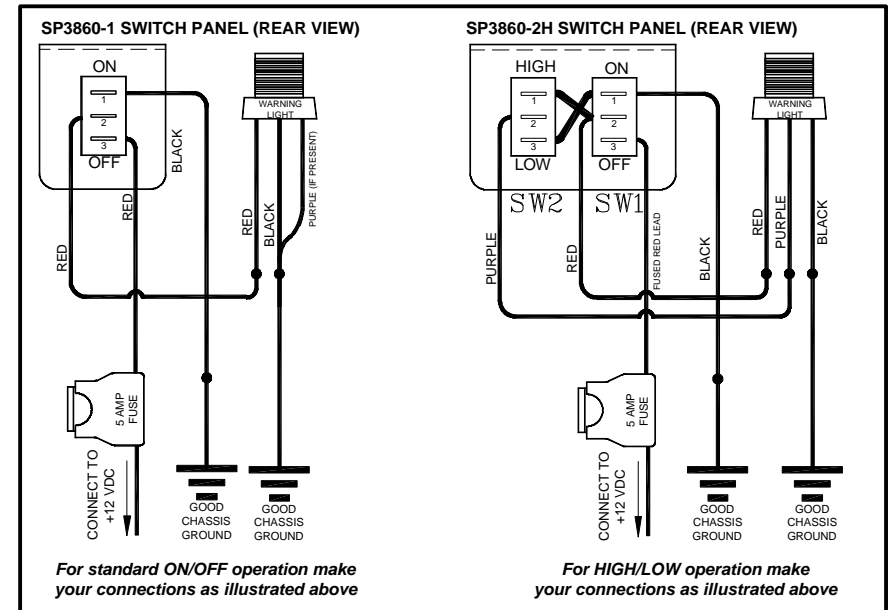

## ONE YEAR LIMITED WARRANTY

The manufacturer warrants each new product, under normal use, against factory defects in material and workmanship for one year after the date of purchase. The owner will be responsible for returning to the Service Center any defective item(s) with the transportation costs prepaid. The manufacturer will, without charge, **repair or replace at its option**, products, or part(s), which its inspection determines to be defective. Repaired or replacement item(s) will be returned to the purchaser with transportation costs prepaid from the service point. A copy of the purchaser's receipt must be returned with the defective item(s) in order to qualify for the warranty coverage.

Exclusions from this warranty include, but are not limited to, bulbs, strobe tubes, domes, and/or the finish. This warranty shall not apply to any light, which has been altered, such that in the manufacturer's judgment, the performance or reliability has been affected, or if any damage has resulted from abnormal use or service. This warranty does not apply to defect or damage occurring as a result of disaster, accident, abuse, misuse, lightning, power surges, or failure to follow instructions in any enclosed manuals. Any damage or defects occurring as a result of any unauthorized service or repairs by unauthorized persons shall be excluded from this warranty.

There are no warranties expressed or implied (including any warranty of merchantability or fitness), which extend this warranty period. **The loss of use of the product, loss of time, inconvenience, commercial loss or consequential damages, including costs of any labor, are not covered.** The manufacturer reserves the right to change the design of the product without assuming any obligation to modify any product previously manufactured.

This warranty gives you specific legal rights. You might also have additional rights which may vary from state to state. Some states do not allow limitations on how long an implied warranty lasts. Some states do not allow the exclusion or limitation of incidental or consequential damages. Therefore, the above limitation(s) or exclusion(s) may not apply to you.

If you have any questions concerning this or any other product, please contact our **Customer Service Department** at (585) 226-9787.

*If a product must be returned for any reason, please contact our Customer Service Department to obtain a Returned Goods Authorization Number (RGA #) before you ship the product back. Please write the RGA # clearly on the package near the mailing label.*

**STAR**  
WARNING  
SYSTEMS

**Star Headlight & Lantern Co., Inc.**

455 Rochester Street  
Avon, NY 14414  
Phone: 585-226-9500  
Toll Free Fax: 888-478-2797



www.star1889.com



REV. E 3/16/04

PLITSTR44