

# *Star Mini Phantom*<sup>TM</sup>

## Interior Undercover Mini LED Light

PATENTS D530,029 and D632,421

### ULB9LDC Series

(Lineum LED Dual Color)



**IMPORTANT:** Please read all of the following instructions before installing your new light.

**CAUTION:** Please be sure to check that your cigarette plug outlet or hard wire is properly fused with a 5 amp fuse. **Testing the light before this fuse is properly installed will void the warranty on the light.**



**WARNING!**

This light utilizes high-intensity LED Lamps. **DO NOT** stare directly into the light while it is on, as momentary blindness and/or permanent eye damage may occur.



PROUDLY MADE IN THE USA  
An ISO 9001:2008 Certified Company

### NOTICE

Due to continuous product improvements, we must reserve the right to change any specifications and information, contained in this manual at any time without notice. Star Headlight & Lantern Co., Inc. makes no warranty of any kind with regard to this manual, including, but not limited to, the implied warranties of merchantability and fitness for a particular purpose. Signal Vehicle Products, Inc. shall not be liable for errors contained herein or for incidental or consequential damages in connection with the furnishing, performance, or use of this manual.



**Star Headlight & Lantern Co., Inc.**

455 Rochester Street Avon, NY 14414 Phone: 585-226-9787 FAX: 888-478-2797

**STAR**  
WARNING  
SYSTEMS

**STARSIGNAL**  
VEHICLE PRODUCTS

**BRADFORD**  
Vehicle Solutions

[www.starheadlight.com](http://www.starheadlight.com)

PLIT530 REV. C 4/14/16

**Please Note:** These instructions are provided as a general guideline only. Specific mounting, wiring, and/or weather-sealing may be necessary and are the sole responsibility of the installer. Star Headlight assumes no responsibility for the integrity of the installation for this or any of its products.



Care should be taken when positioning any warning light on the roof, dash, or instrument panel of the vehicle, so that the light and/or cord does not interfere with the proper operation of any airbags! Failure to heed this warning may result in serious or fatal injury.



**This light is designed to be mounted on the inside of your vehicle. It is not intended for exterior applications and is not warranted against water damage.**

*It is the sole responsibility of the owner to ensure the warning light is secure. Check your light every time you enter the vehicle to ensure that it is mounted securely. The manufacturer assumes no responsibility for the secure mounting of this light.*

## Parts

- 1 Starburst Mini Phantom Head
- 1 ULB9-HOOD-1 Flashback Hood with Windshield Brackets
- 1 S111-6 Hood Gasket
- 1 PLABULB9 Reflective Hood Label
- 2 P30019-267 Pivoting Flush Mount Brackets

### INCLUDED



Mini Phantom Head  
w/Lineum LEDs

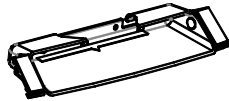

ULB9-HOOD-1 Hood  
w/Windshield Brackets

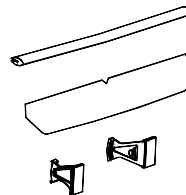

S111-6  
Hood Gasket

PLABULB9  
Reflective Label



P30019-267  
Pivot Brackets for  
Flush Mounting ULB9S

### OPTIONAL



P30047-166 (OPTIONAL)  
Foam Flashback Gasket  
for Flush Mounting

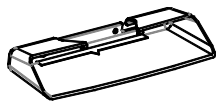

ULB9-HOOD (OPTIONAL)  
Hood for use with  
ULB9-BKT Bracket  
or 274-ULB9MMC

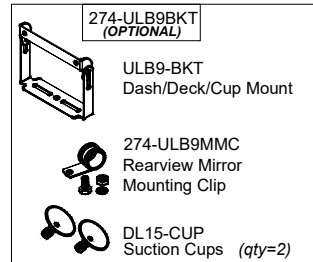

274-ULB9BKT  
(OPTIONAL)

ULB9-BKT  
Dash/Deck/Cup Mount

274-ULB9MMC  
Rearview Mirror  
Mounting Clip

DL15-CUP  
Suction Cups (qty=2)

## Mounting

### Front Windshield Adhesive Mount

1. The hood can be installed such that the cord can exit either side.  
Route the cord through the appropriate slot and slide the hood onto the back of the light until the hooks on the hood "latch" onto the light.

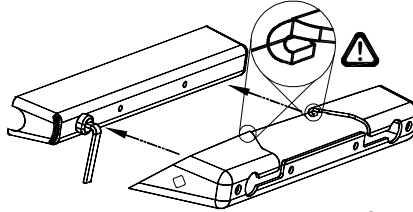

2. If desired, install the rubber gasket along the edge of the hood to help reduce vibration against the window, as well as to allow for minor adjustments to the curvature of the window.

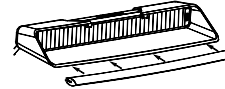

3. Hold the light up to your windshield to test fit the best location for the light, typically high on the windshield touching the headliner.



**DO NOT MOUNT ON DEFROSTER LINES!!**

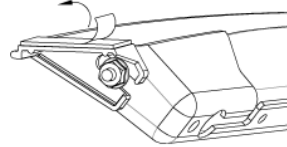

4. Clean your windshield with alcohol and ensure it is dry.
5. Remove the tape liner from both brackets on the light.
6. Place light in the chosen location pressing firmly on the brackets ensuring maximum contact and adhesion.
7. With the brackets in place and secure, loosen both nuts only enough to slide the light snugly against the windshield and then retighten.

**CAUTION: Take extreme caution not to over tighten the nuts!!! Over tightening of the nuts can strip the holes and result in a faulty mount.**



**Because it takes about 72 hours or 3 days for the adhesive to reach full bonding potential, check the light often during this period to ensure the tape maintains full contact with the bracket and glass.**

### Light Replacement

If you need to replace your light for any reason, you can leave the brackets affixed to the window and remove the light from them.

1. Loosen both nuts only enough to slide the light out of the slots in the brackets. The brackets will remain attached to the windshield.
2. Install new light by sliding it back into place in the bracket slots.  
Note - insure square head of carriage bolt is within bracket slot.
3. Tighten both nuts. Note - Do not over tighten nuts as doing so may cause the carriage bolt head to spin in the hood.

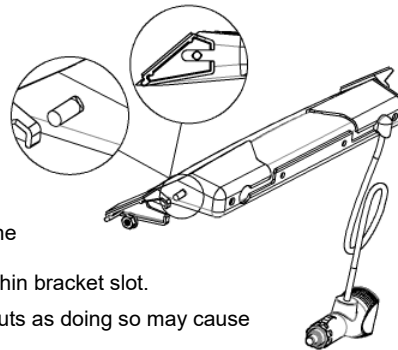

### Bracket Removal

Over time the bracket adhesive bond becomes stronger. If the procedure below doesn't work it may be necessary to use alcohol or WD40 to soften the adhesive in combination with the steps below.

1. Remove the light head as described under *Light Replacement*.
2. Using razor blade scraper, carefully scrape the adhesive tape off the window gently prying the bracket away from the window until it is removed.

(ULB9S Mounting CONT'D)

### Optional Reflective Hood Label Installation



**Practice installing label BEFORE removing backing.**

1. Align the notch in the label with the center of the hood taking care that the front edge of the label lines up with the front edge of the hood.
2. Hold one half of the label firmly in place with the backing still affixed.

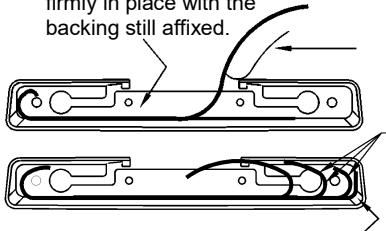

3. Slowly start to peel the backing off of the other half of the label from the center out.
4. Gradually peel the backing off of the rest of that half of the label carefully rolling it into place along the hood.

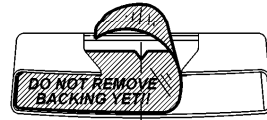

5. Using your finger or other cylindrical object, carefully "roll" the label through the corner ensuring that no air bubbles form. If your hood has bolt heads inside, smooth the label or cut it as needed.
6. Repeat the process to affix the other half of the label to the hood.

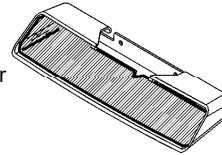

### Flush Window Adhesive Mount

1. Snap one pivot bracket onto each side of the light.

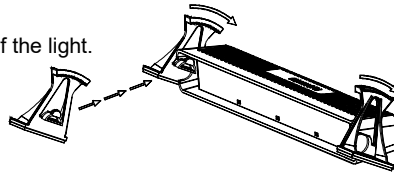
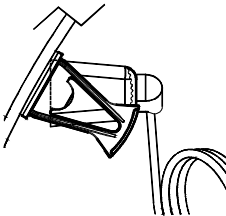

2. Select a location for your light and hold the light up to the window adjusting the pivots such that the light is approximately level.



**DO NOT MOUNT ON DEFROSTER LINES!!**

3. **Thoroughly** clean your windshield with alcohol and ensure it is dry.

4. Remove the backing from the double sticky tape on the light and place the light in the chosen location pressing **VERY LIGHTLY** on just the brackets. Check the light from the front and back to verify placement. If placed correctly, press firmly on the brackets ensuring maximum contact and adhesion. *Note - if a placement mistake is made, quickly remove light by levering off the brackets with a flat blade screwdriver.*

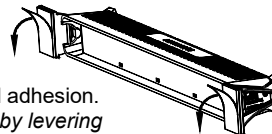

**Because it takes about 72 hours or 3 days for the adhesive to reach full bonding potential, check the light often during this period to ensure the tape maintains full contact with the bracket and glass.**

## Optional Bracket Mounting (Deck, Mirror, or Suction Cup)

(Optional mounting kit 274-ULB9-BKT sold separately)

1. Decide which side you want the cord to exit the light and determine which way you will need to mount the ULB9-BKT to your light.
2. Attach Part A of the mounting bracket, facing the direction you have selected, to the light by using two of the Philips head screws.

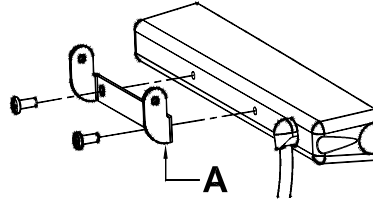

**CAUTION: Take extreme caution not to over tighten the screws!!! Over tightening of the screws can strip the holes and result in a faulty mount.**

3. Use two Philips head screws, two flat washers, and two tooth washers to attach Part B of the mounting bracket to Part A.

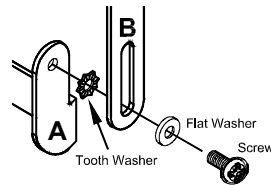
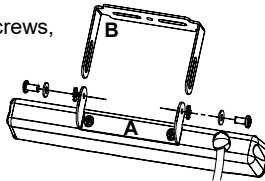

4. If you are mounting the light directly to the rear deck, dash, or other suitable surface, you may use appropriate fasteners (not supplied) to attach the bracket to your mounting surface and skip to step 9.

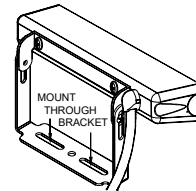

5. If you are utilizing the suction cup mount, attach the suction cups to the mounting bracket. Then mount the light in the desired location and skip to step 9.

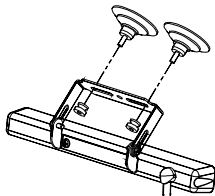

**CAUTION: Take extreme caution not to over tighten the suction cups!!! Over tightening of the screws can strip the holes or puncture the inside of the cup resulting in a faulty mount.**

6. If you are using the Mirror Mounting Clamp to mount your light to your rear view mirror, it is the sole responsibility of the installer to ensure that the rear view mirror mount can support the light you are installing.

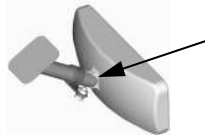
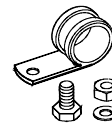

7. Place the clamp around the mirror stem.

8. Attach the clamp to the bracket with the washer, nut and bolt, securing your light to the rear view mirror.

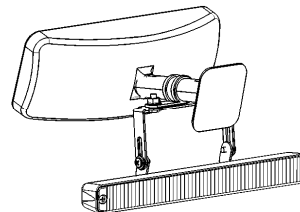

9. Once the light is secured, route your cord such that it does not interfere with the vision of the driver or the operation of the steering wheel, gear shifter, and/or any airbags.

## Connections and Operation

### ULB9LDC (cig plug version only)

The **ULB9LDC** (cig plug version) can be left plugged into the outlet in your vehicle. Either function can be turned on and off using the lighted power switches on the cord.



**Note:** If one of the patterns is set for Steady, it will override the other if both colors are activated. If both are flashing patterns, then they will alternate.

These lights have been factory tested and approved. If the light fails to work when the plug is inserted into the cigarette plug, check the following

- Check the ON/OFF rocker switch on the cig plug to be sure it is in the ON position.
- Twist the plug a few times to remove any ash or other deposits which might be preventing a good contact from being made.
- Remove the fuse from the vehicle fuse box and check to see if it has blown.
- Remove the fuse from the cig plug on the light (if present) and check to see if it has blown.
- Clean the lighter socket and contact surfaces.

### ULB9LDC-1 (hardwired version only)

The **ULB9LDC-1** (hard wire) should be wired through a 5 amp fuse (not supplied) and a 12VDC switch (not supplied) capable of handling at least 5 amps. Connect the wires as follows:

**Black** - Good Chassis Ground

**Red** - Power (+12 VDC) for Function 1/Color 1

**Green** - Power (+12 VDC) for Function 2/Color 2

**White** - Synchro: AFTER PROGRAMMING, Connect the white wires from the two lights together to synchronize them together.

## Programming

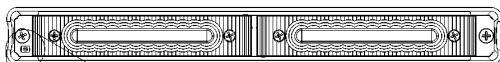

There is a **Programming Button** located on the front of the unit that is used to program the desired output options.

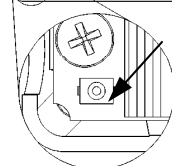

### FULL/SPLIT MODES

By default, the lights are programmed for the two halves of the light alternate with one another (Split Mode). If you would like to change this setting so the entire light flashes at the same time (Full Mode), hold the Programming Button until the light blinks 7 times (~21 seconds). Repeat to change the functionality back to its original setting. Review the diagrams to the right to see the various outputs, depending upon the model you have and the way that they are programmed.

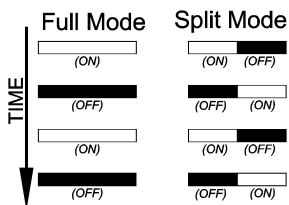

(Programming CONT'D)

**PATTERNS**

The ULB9LDC Series lights are designed with 12 different *patterns* in one of two *phases*. The second phase is identical to the first, but flashes opposite from the first. It will only be noticeable when synchronizing two of the ULB9LDC-1 lights (*hardwire versions only*). After the final pattern is reached, the patterns will cycle through again.

To change the pattern, **only activate the function you wish to program** and then press and release the Programming Button to scroll through the patterns.

Repeat for the other function, if desired.

Phase 1 Flash Pattern	Phase 2 Flash Pattern	Pattern Type	Pattern Description	Shortcut
1	13	A12	Flicker † (Default Pattern)	←
2	14	L	Fast Doubleflash	Pattern 1 (Phase 1): 3 sec or 1 flash
3	15	M	Tripleflash †	Pattern 13 (Phase 2): 9 sec or 3 flashes
4	16	A13	Post-Pop Triple x 2 †	
5	17	A14	Alt. Flicker, Double, Post-Pop	
6	18	A15	Quadflash †	←
7	19	A16	Quadflash w/Post-Pop †	Pattern 6 (Phase 1): 6 Sec or 2 flash
8	20	H	Singleflash †	Pattern 18 (Phase 2): 12 sec or 4 flashes
9	21	A17	Doubleflash †	
10	22	J	Variable AKA Delta-Omega	
11	23	C	Post Pop †	
12	24	E	Random	
NA			Steady	18Sec

**Pattern Shortcuts:**

Hold Programming Button for indicated time.

**White:**

If your secondary color is white, by default it will be programmed for Steady Burn mode.

**Steady Burn:**

Not in pattern cycle. Only accessible through shortcut. Press the Programming Button for 18 seconds (light will flash 6 times)

† Meets J595 Class 1 specifications in all configurations excluding red in split mode.

**SYNCHRONIZATION**

You can synchronize up to 6 lights with **LINK SYSTEM** compatibility, using the same Pattern Type.

**DO NOT CONNECT WHITE WIRES UNTIL PROGRAMMING HAS BEEN COMPLETED FOR ALL LIGHTS!!**

1. Power up the first unit and select a Phase 1 pattern. Press and release the Programming Button to change patterns.

2. Program the second light with the same **Pattern Type**.

Lights with the SAME phase flash together (simultaneous).

Lights with DIFFERENT phases flash opposite one another (alternate).

3. After programming all lights, connect the white wires together.

4. Test lights by applying power to all of them at the same time.

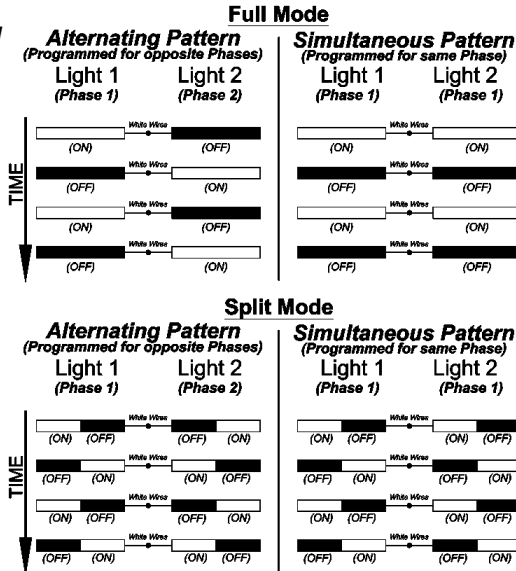

**FOR SYNCHRONIZATION BOTH LIGHTS MUST BE SET FOR THE SAME PATTERN TYPE!**

### **DUAL-FUNCTION FLASHING MODE**

The ULB9LDC Series lights do have an option that will allow you to program either switch (or power wire) to automatically activate BOTH functions/colors to flash opposite of one another. To do this proceed as follows:

- Turn on the switch you want to use to activate dual-color flashing.
- Hold the Programming Button down until the light flashes 8 times (~24 seconds), then release it.

The other switch can still be used to activate the single function it controls (may be flashing or steady burn).

**Please note:** *By default, because your light is shipped in Split Mode, when you activate Dual-Function Mode, your light will be in POP Mode (see below).*

### **POP MODE (Only applies to lights in split Mode)**

When the ULB9LDC is in both "Split" mode **AND** "Dual Function Flashing" mode, the light will automatically go into Pop Mode. This feature will flash the opposite side with a quick "pop" of the secondary color (ideally white). Deactivate Split Mode to turn off this mode with Dual-Function Flashing.

### **STEADY BURN PROGRAMMING**

1. Hold the Programming Button until the light blinks 6 times (~18 seconds), then release it.  
For lights in *Split Mode*, one half will become steady, while the other flashes.

- To change the pattern on the flashing side, press and release the Programming Button.
- To flip-flop the steady side and the flashing sides, hold the Programming Button until the light flashes 5 times (~15 seconds) and then release it.

For lights in *Full Mode*, the entire light should illuminate steady burn.

2. To exit Steady burn pattern: **Split Mode** - Hold the Programming button until the light blinks six times (approximately 18 seconds).

**Full Mode** - Touch and release the Green wire to Ground.

### **LED FIVE YEAR LIMITED WARRANTY**

The manufacturer warrants this LED light against factory defects in material and workmanship for five years after the date of purchase. The owner will be responsible for returning to the Service Center any defective item(s) with the transportation costs prepaid. The manufacturer will, without charge, repair or replace *at its option*, products, or part(s), which its inspection determines to be defective. Repaired or replacement item(s) will be returned to the purchaser with transportation costs prepaid from the service point. A copy of the purchaser's receipt must be returned with the defective item(s) in order to qualify for the warranty coverage. Exclusions from this warranty include, but are not limited to, domes, and/or the finish. This warranty shall not apply to any light, which has been altered, such that in the manufacturer's judgment, the performance or reliability has been affected, or if any damage has resulted from abnormal use or service.

There are no warranties expressed or implied (including any warranty of merchantability or fitness), which extend this warranty period. **The loss of use of the product, loss of time, inconvenience, commercial loss or consequential damages, including costs of any labor, are not covered.** The manufacturer reserves the right to change the design of the product without assuming any obligation to modify any product previously manufactured.

This warranty gives you specific legal rights. You might also have additional rights that may vary from state to state. Some states do not allow limitations on how long an implied warranty lasts. Some states do not allow the exclusion or limitation of incidental or consequential damages. Therefore, the above limitation(s) or exclusion(s) may not apply to you.

If you have any questions concerning this or any other product, please contact our **Customer Service Department** at (585) 226-9787.

If a product must be returned for any reason, please call the Customer Service number listed above and ask for the Repair Department to obtain a Returned Material Authorization number (RMA #) before you ship the product back.. Please write the RMA # clearly on the package near the mailing label.