

---

# INSTALLATION AND INSTRUCTION MANUAL

---



# STARLASER™

## Ultra Low Profile Modular Mini Lightbar



These lightbars contain one or more of the following light sources: Strobe Lights, Halogen Lamps, and/or High Intensity LED Lamps. **DO NOT** stare directly into any of these light sources as temporary blindness and/or permanent eye damage may occur.

### NOTICE

Due to continuous product improvements, we must reserve the right to change any specifications and information, contained in this manual at any time without notice. Star Headlight & Lantern Co., Inc. makes no warranty of any kind with regard to this manual, including, but not limited to, the implied warranties of merchantability and fitness for a particular purpose. Star Headlight & Lantern Co., Inc. shall not be liable for errors contained herein or for incidental or consequential damages in connection with the furnishing, performance, or use of this manual.



**Star Headlight & Lantern Co., Inc.**

455 Rochester Street

Avon, NY 14414

Phone: 585-226-9787

FAX: 888-478-2797

**STAR**  
WARNING  
SYSTEMS

**STAR SIGNAL**  
VEHICLE PRODUCTS

**BRADFORD**  
Vehicle Solutions

[www.starheadlight.com](http://www.starheadlight.com)

PLIT441 REV. B 11/30/15

## **Mounting Instructions**

Please review the separate Mounting Bracket manual that is also enclosed with your bar for mounting instructions.

## **Wiring Instructions**

**PLEASE NOTE:** If you need a cable longer than the existing 15-foot harnesses supplied with the lightbar, it is recommended that you completely replace the harness, rather than adding on to it. Please see the Wire Harness Replacement section on pages 3-4.



### **RF INTERFERENCE**

Please take the following steps to help eliminate any Radio Frequency Interference (RFI) with your two-way radio.

- **DO NOT** run the power wire for the lightbar along same path as any antenna wires.
- **DO NOT** run the power wire for the lightbar along same path as any radio power wires.
- **DO NOT** tap power for the lightbar off of the radio power wires.
- **DO NOT** mount the lightbar within 20" of any antennae. Sometimes mounting the lightbar or antenna over by just one foot can make a large difference in the interference.
- Ensure the black wire from the lightbar has a good connection to the **negative side of the battery.**

- All standard Mini Laser lightbars have a 15' harness. It has 10-conductors (plus a drain wire and a foil shield). All wires are color coded and sized at the correct gauge. If this length is not sufficient, it is recommended that the wire harnesses be completely replaced, with the only connections to be made directly at the terminal blocks inside the lightbar. This will reduce the number of wire connections and help prevent any weathering problems on these connections. Refer to the *Wire Harness Replacement* section on the page 3-4 for further instructions on this.
- **CAUTION: All wires and switches should be rated for at least 125% of their maximum current load.** In addition, the red power wire should be connected to the positive terminal of the battery and fused at the battery for 125% of its rated load. The current for each component is shown on the Parts list on page 7. **Do not use** a 1/4" diameter glass fuse, as it is not suitable for continuous duty above 20 amps. If you are unsure of the current draw, please contact our Customer Service Department.
- **TESTING THE LIGHTBAR BEFORE IT IS PROPERLY FUSED WILL VOID THE WARRANTY!!**
- The black ground wire should be connected to the negative terminal of your vehicle's battery. This wire should be at least #14 AWG wire and be as short as possible in order to minimize the voltage loss in this wire and reduce any chance of overheating.
- The *Wire Connection* section and diagram on the next page lists the different wire colors and the lights controlled by those wires. Your harness WILL contain all 10 of the colored wires, the drain wire, and a foil shield, although they will not all be utilized.

(Wiring Instructions CONT'D)

## Wire Connections

### Harness Wire Colors

<b><u>Feature</u></b>	<b><u>Apply +12VDC to:</u></b>
Main Power	Red
Pattern Select	Red w/Green ( <b>TEMP</b> )
<b><u>Feature</u></b>	<b><u>Connect to Ground:</u></b>
Low Power	Purple
<b><u>Lightbar Location</u></b>	<b><u>Apply +12VDC to:</u></b>
Front	Orange
Rear	Brown

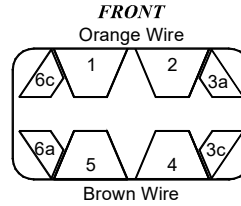

Connect the appropriate wires from the Wire Harness to your switchbox (user provided). Whenever +12VDC is applied to the Orange or Brown wires, the corresponding heads will be activated (as long the red wire is connected to +12VDC and the black wire is connected to the negative side of the battery).

**Note:** The bare "drain" wire should be connected to a good chassis ground.

**Black Wire:** Connect to the negative side of the battery.

**Red Wire:** Connect to the positive terminal of the battery through a fuse at the battery for 125% of the rated load of all your components. The current for each component is shown on the Parts list on page 7. **Do not use** 1/4" diameter glass fuses, as they are not suitable for continuous duty above 20 amps.

**Please Note:** When the red wire is connected to +12VDC the lightbar will draw a small current (~100 mA). If your vehicle will be sitting for extended periods of time (i.e. more than a few days), it is recommended the red wire be routed through a switch or ignition switched relay.

**Red w/Green Wire:** Pattern Select wire - see the **LED Flash Pattern Selection** section on page 6.

**Purple Wire:** Used if you need the ability to switch your lightbar to low power at night. Leave this wire disconnected to run on constant high power. Connect it to ground through a switch to allow switching to low power (low when purple connected to ground).

**Note:** The low power setting decreases the light output of emergency warning lights, thus reducing their effectiveness. Star does not recommend the use of low power mode in brightly lit areas (including daylight). Lightbars running on low power may not comply with applicable emergency warning light standards and/or specifications.

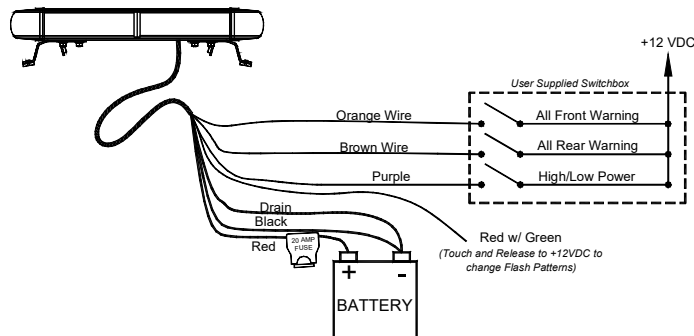

## Wire Harness Replacement

***If you are using the existing 15-foot harnesses supplied with the lightbar, you may skip to the LED Head Programming section on page 5.***

Standard Mini Laser lightbars come with a 15-foot wiring harness. If the harness supplied with the lightbar is not long enough for your application, Star recommends ordering the proper cable of the desired length from the factory. Completely remove the pre-installed wire harness(es) and replace it (them) with one that is the correct length.

- *Star recommends direct wiring to the terminal block(s) on the inside of the lightbar, rather than making connections to the end of the wire that is supplied.*
- *This lightbar is designed so that when replacing the wire harness(es), no wire connectors are needed and only a few common tools are necessary.*
- *Direct wiring allows the wire connections to the lightbar to be made in a clean and dry environment, avoiding any problems that may arise due to weathering on external connections.*
- *Wiring directly inside the lightbar reduces the number of connections. There is an increase in voltage loss with the addition of each connection.*
- *Making connections to the wires already provided is an acceptable alternative, as long as these connections are good electrical connections and are resistant from weathering effects.*

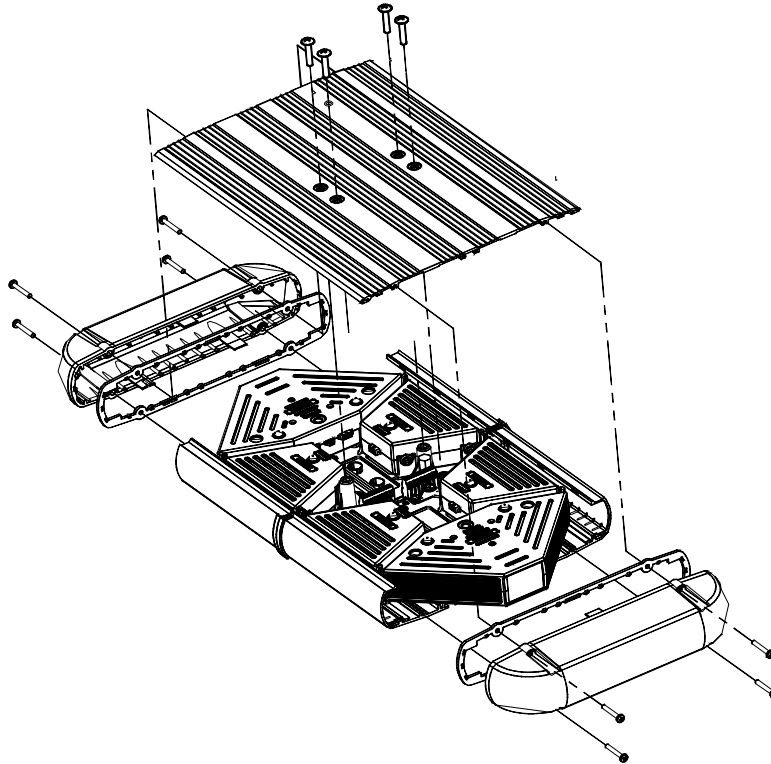

*(Wire Harness Replacement CONT'D)*

1. To replace the wire harness you will need to access the inside of the lightbar. Remove the endcaps by removing the four screws from each end and the screws that hold the top extrusion on the lightbar (ex. 6 screws on a 46" lightbar), and carefully lift the top off of the lightbar (as shown on the previous page).
2. Locate the end of the lightbar with the wire harness attached to it. The terminal blocks, which you will be making your wire terminations to, are also located at this same end. The two harnesses enter the bar through separate openings and are each fastened to the extrusion with a small clamp.
3. Remove the screw that attaches the cable clamp to the extrusion.
4. Loosen the screws that secure the wires in each terminal block, and slide the old harness(es) out through the inlet.
5. Run the new external harness up through the wire bushing into the base and into the terminal blocks. **Take extreme caution** that none of the wires frays at the end, shorting out to the adjacent terminal and/or adjacent wire.
6. Strip each wire 1/4". Connect each wire to the proper terminal, as indicated in the diagram below, by inserting the stripped portion of the wire under the rising clamp screw and tightening down the screw. No wire terminals are needed for connecting wires to this terminal block.

**Be sure to check that no strands of wire are loose and shorting to the adjacent terminal or to the base of the lightbar.**

7. Once your new wire harness has been connected to the lightbar, secure it with the cable clamp and reassemble the top extrusion and endcaps. Then you may go back to the *Wire Connections* section.

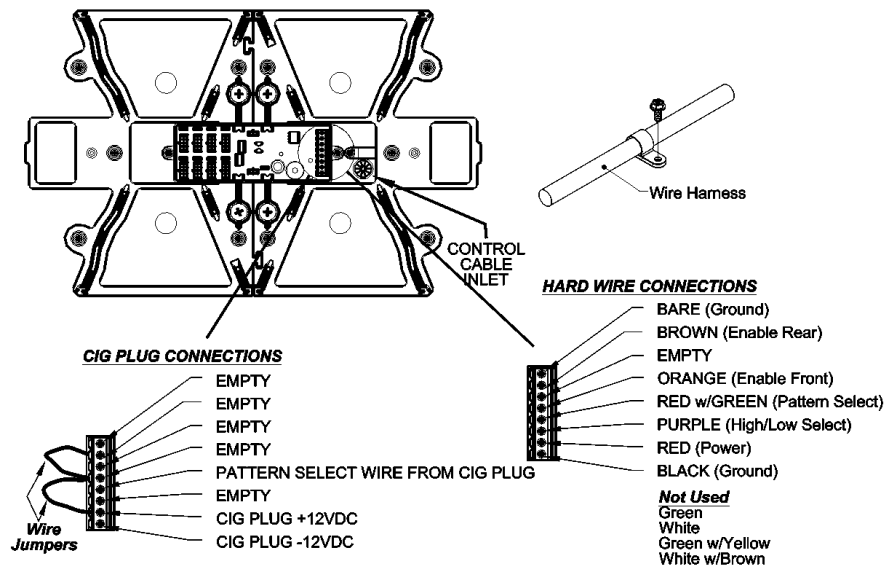

## LED Head Programming

*If your lightbar came pre-configured with LED heads, the LED heads will already be pre-programmed with a default Flash Pattern and appropriate Phases and you are finished.*

*If you are installing new heads, or wish to change the Flash Pattern and/or Phases of specific heads, proceed below.*

- LED heads can be programmed with the user's choice of "phase". Each light head in the Laser lightbar can be set for one of two phases. Two heads that are set for the same phase will flash at the same time (simultaneous) and two heads set for opposite phases will flash opposite of one another (alternating).
- LED heads can also be programmed with the user's choice of flash pattern. We have designed the LED heads in the Laser lightbar to have 10 programmable patterns. If you have multiple LED heads that are all activated by the same color control wire (see page 2), they will be programmed together. Any of the LED heads that will be utilizing the same pattern should be programmed together. Do so by activating all of the appropriate control wires together, and then programming them. LED heads using different control wires can also be programmed separately, if you desire different patterns for each.
- Prior to adjusting these settings, Star recommends illuminating the bar to determine if the preset phase and pattern settings are acceptable. If you activate the bar and decide that you'd like to change either the phase or pattern settings, proceed below.

### Phase Selection

1. Remove the top extrusion from the lightbar as described on page 3, under the **Wire Harness Replacement** section.
2. Locate the communications board inside the lightbar. At one end you will find terminal blocks into which all of the wires from your harnesses run. Located towards the other end you will notice twenty (20) small connector blocks. Each of these connectors will then have a small harness that runs to the corresponding head location inside the lightbar (i.e. Connector 1 controls Head 1, Connector 2 controls Head 2, etc.).
3. Above each connector you will find the Phase Jumper. This jumper will determine which phase that particular head will flash in. All of the heads that have the jumpers on the left two pins will flash on and off at the same time (if their control wires are activated). All of the heads with the jumpers on the right two pins will also flash together with one another, but they will also be flashing opposite the heads with the jumper on the left two pins.

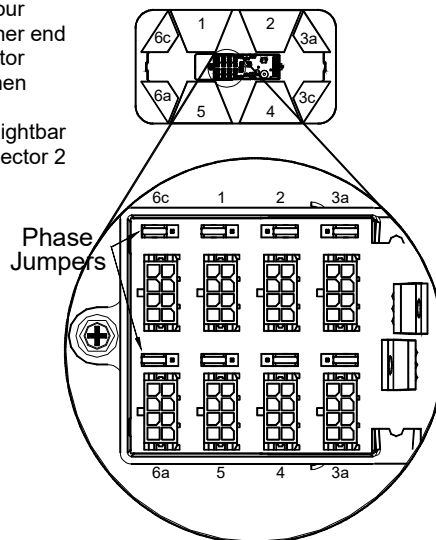

(LED Head Programming CONT'D)

### LED Flash Pattern Selection

1. To program the flash pattern, activate the LED heads that you wish to program by applying +12VDC to the appropriate control wire. (The red wire should already be connected to constant +12VDC, and the black wire should be connected to the negative side of the battery).
2. Briefly touch the red w/green stripe wire to +12VDC and release it once ALL of the heads go out. Continue to briefly touch and release this wire to +12VDC until you find the pattern desired.
3. Once you have the pattern you like, turn the heads off. The heads will remember the pattern next time it is activated.
4. Repeat steps 1-3 for each additional heads you wish to program.
5. Once your programming is complete, tape the end of the red w/green stripe wire so that it does not come into contact with +12VDC.



















### LED Flasher Patterns

<b>Pattern</b>	<b>Warning Pattern Style</b>
1	Alternating Slow Single
2	Alternating Fast Single
3	Pursuit Mode ( <i>Alternating Quint Burst with Fast Alternating Single Flash</i> ) - <b>Default Pattern</b>
4	Unsynchronized Quint Burst with Fast Alternating Single Flash ( <i>Phase 1</i> )
5	Unsynchronized Quint Burst with Fast Alternating Single Flash ( <i>Phase 2</i> )
6	Steady Burn
7	Alternating Quintflash
8	Alternating Fast Doubleflash
9	Pursuit Mode 2 ( <i>Alternating Quint Burst , Fast Alt. Single Flash, Fast Alt. Doubleflash</i> )
10	Alternating Doubleflash w/Post Pop

**SHORTCUT:** At any time during the programming sequence, you can reset the flash pattern back to the default mode (Pattern 3 – Pursuit) by holding the red w/green Pattern Select wire to +12VDC for 3 seconds, then releasing it after the light flashes once.

**Please note:** If you do NOT release the wire after 3 seconds, once the bar reaches 6 seconds it will flash again and set the lights into an unsynchronized pattern that is typically NOT desired. If you accidentally enter this mode, simply repeat the LED Flash Pattern Selection instructions and use the 3 second shortcut to go back to the default pattern (#3).

## Replacement Parts

	720-23* END DOME		30019-124 FRONT/REAR BLOCK OFF PLATE
	720-23C/O* END DOME		720-3* (0.4A) STARBURST LED LIGHTHEAD
	720-21M* MEDIUM SIDE LENS		720-3*BO3* (0.8A) STARBURST END LED LIGHTHEAD w/CENTER BLOCK OFF
	30047-101 END DOME GASKET		720-9* (0.4A) LINEUM LED LIGHTHEAD
	720-22 SIDE LENS CLIP		720-9*BO9* (0.8A) LINEUM END LED LIGHTHEAD w/CENTER BLOCK OFF
	30047-100 SIDE LENS CLIP GASKET		720-39 DIRECT MOUNT KIT
	30047-104 EXTRUSION/LENS GASKETING (1 FOOT)		HOOK MOUNTS THESE ARE PICTURED IN THE HOOK MOUNT MANUAL AND WORK IN CONJUNCTION WITH THE 720-39. *=COLOR
	P30047-131 FOAM GASKETING FOR EXTRUSION SLOTS (1 FOOT)		
	30054-8 #10 x 1" END DOME SCREW		
	30056-35 1/4"-20 X 1-1/4" TOP EXTRUSION SCREW		
	30076-10 TOP EXTRUSION SCREW O-RING		

*Please note that these items are not drawn to scale.*





**CAUTION:** High voltages can exist in many of our products. Before attempting service on any of our products, be sure to disconnect power for at least five minutes to allow any capacitors to discharge. Failure to heed this warning may result in severe electrical shock and/or injury

**Please Note:** Many failures can be traced to wiring and/or battery problems. Before attempting service on the product itself, please be sure to check all connections and wiring to ensure that the correct voltage and/or polarity is reaching the faulty device.

## ***Troubleshooting Guide***

*If a light on your bar fails to work, please refer to this section to help solve your problem. If you still cannot resolve your problem, please contact our **Customer Service Department** at 585-226-9787.*

The chart below contains some basic guidelines for troubleshooting any problems you may experience with your bar. The section following the chart will explain in further detail how to perform some of the troubleshooting tasks.

<b>Symptom:</b>	<b>Possible Solutions</b>
One single LED light is Out	LED Head needs to be replaced
One head does not flash or illuminate	If it uses a halogen bulb, check the bulb Check mini harness between Connector Board and defective head to see if it is loose (not fully inserted) or damaged If the control wire for that head only controls 1 head, check that +12VDC is applied to the appropriate control wire. Check head
Multiple heads not flashing or illuminating	Check power to terminal block Check that the bar is properly grounded Check that +12VDC is applied to control line for those heads Check that the red w/green stripe pattern select wire is not connected to +12VDC



*When mounting your lightbar, please be sure to keep any radio frequency sensitive equipment at least 20" from the bar and power cable(s). This is especially critical in lightbars utilizing strobes. Our strobe power supplies have been designed to limit RFI emissions, but certain very sensitive equipment may still be affected. Symptoms may include, but are not limited to, sporadic operation and degraded performance. Star Headlight & Lantern Co., Inc. cannot assume any responsibility for any radio frequency induced malfunction or damage to any radios, sirens, lightbars, or any other equipment mounted within 20" a strobe lightbar. Any antennae mounted in the proximity of the lightbar may cause your radio to suffer the aforementioned results.*

**Determining if the bar is properly grounded:**

1. While the bar is turned on, using a test meter, measure the voltage from the base of the bar itself to the negative post of the battery or a good chassis ground if the battery can't be easily reached. You may need to scrape away a bit of anodizing or paint in order to ensure a good connection with the probe of your test meter.
2. If the difference shown is greater than .25 volts, then your ground is not sufficient.
3. If the ground is insufficient, locate the ground wire connection in your lightbar by removing the top extrusion (see page 3), exposing the area where the wires enter the bar. The ground wire is the large (10AWG) black wire found in the Power Wire Harness. Check the integrity of the connection of the ground wire to both the terminal block inside the lightbar and at the other end to the negative side of the battery.
4. While inspecting the ground wire connections you should also check that the wire itself is not damaged. Carefully inspect the wire along its entire length, paying special attention to those areas where the wire passes through any holes that may have sharp edges, which can damage the wire, and the areas where the wire makes any sharp bends.

**Checking the power to the terminal block  
(Determining if the proper voltage is reaching your bar):**

1. Locate the terminal block in your lightbar by removing the top extrusion and endcaps (see page 3). After the harnesses enter the bar, the wires will be connected to the terminal blocks with a number of small screws.
2. With the bar turned on (all control wires activated), use a test meter to test the voltage at the terminal block, for each individual wire. A nominal 12.5 volts should be present (except for the black wire, red w/green stripe, and purple wires). Low voltage can cause erratic flashing in strobe heads or even complete failure of the heads. A minimum of 10 volts should be present for the heads to operate properly. Low voltage can result in lowered intensity or even complete failure.
3. Be sure to test each wire that comes into the terminal block for proper voltage.
4. Carefully inspect each wire in the terminal block. Check that the ends of the wires have not frayed and shorted against one another or against the base. This may cause lights to operate inadvertently or may result in the failure of lights.

**Checking one non-working head:**

*If a problem exists in only one head*, the head may be defective, or there may be an open electrical connection or short in the mini harness.

1. Disconnect the mini harness from the back of both the faulty head and a working head. Carefully lift them both out of the lightbar and place the faulty head in the location the working head previously occupied.
2. Plug the mini harness that was formerly connected to the good head, into the back of the faulty head.
3. Activate the wire/function that controls that particular head location in the lightbar (see pg. 2).

**If the formerly faulty head now works in the new location**, the problem lies in the other mini harness (connected to the location that this head was formerly in). Verify this by plugging the other head (the original good head you just unplugged) into the position that previously had the non-working head. It should also fail in this position. If so, check connections at and between the Connector Board and the faulty head. If necessary, replace the defective mini harness.

**If the faulty head still does not work**, then the problem lies in the head itself. If the head contains a halogen bulb, check that the bulb is still good. If the head uses a different light source (i.e. LED or strobe), then the head must be replaced.

**Checking multiple non-working strobe or LED heads:**

*If two or more of the heads connected to the same switch are not flashing, follow these steps to determine the problem:*

1. Check that the bar is grounded properly as explained on the previous page.
2. Check all fuses, including those at the battery, at the switch panel, and in the dash (if applicable). Remove these fuses, and check them to confirm they have not blown. Replace any blown fuses with only fuses of identical values. Replacing the fuse with the wrong rating may damage your pack and/or vehicle, and will void your warranty.
3. Check that there is NO VOLTAGE on the Red w/Green Stripe wire (Pattern Select wire). Measure the voltage at the terminal block between the Red w/Green stripe wire and a good chassis ground. If there is voltage being applied to this wire, it will prevent the heads from flashing.
4. Check the power on the red power wire and the corresponding control wires at the terminal block as explained on the previous page. If sufficient voltage is not reaching the terminal block perform the following tests:
  - a. With the vehicle turned off and while the pack is running, measure the battery voltage *at the battery*. A nominal 12.5 volts should exist. Note this voltage. If this voltage is below 10.0 volts the bar will not function properly and the problem is with the battery. This reading should not be more than 1-1.25 volts higher than the reading taken from each wire at the terminal block. If there is an excessive difference then continue on to the next step.
  - b. With the vehicle not running and the lightbar on, measure the voltage in the red wire by taking a reading from the positive side of the battery to pin 1 of your switch. If this reading exceeds 0.25 volts then there is a poor connection between the switch and the battery in the red wire and it should be checked.
5. If the leads in one of the heads have shorted out, the output voltage of the other heads may be held down as well. To test for this, unplug all of connectors for all of the faulty heads **at the Connector Board**, and plug them in individually, one at a time. If your problem is a result of a shorted head (or harness), then the other heads should function properly if the faulty head is no longer connected. Note: A burned out strobe tube does not cause a short and will not affect the operation of the remaining heads.
6. If the problem is with one of the heads and/or mini harnesses, try that non-working head in a different location to determine whether it is the head or harness that is bad.
7. If the problem is not with a shorted head and if proper voltage is reaching the terminal block, then the problem is most likely internal to the "T" shaped Connector Board.

**ONE YEAR LIMITED WARRANTY  
LED FIVE YEAR LIMITED WARRANTY**

The manufacturer warrants each new product, under normal use, against factory defects in material and workmanship for **one year** after the date of purchase. The manufacturer warrants the **LED components** in this light against factory defects in material and workmanship for **five years** after the date of purchase. The owner will be responsible for returning to the Service Center any defective item(s) with the transportation costs prepaid. The manufacturer will, without charge, **repair or replace at its option**, products, or part(s), which its inspection determines to be defective. Repaired or replacement item(s) will be returned to the purchaser with transportation costs prepaid from the service point. A copy of the purchaser's receipt must be returned with the defective item(s) in order to qualify for the warranty coverage. If a copy of the receipt is not provided, the warranty period shall cover five years from the date of manufacture.

Exclusions from this warranty include, but are not limited to, bulbs, strobe tubes, domes, and/or the finish. This warranty shall not apply to any light, which has been altered, such that in the manufacturer's judgment, the performance or reliability has been affected, or if any damage has resulted from abnormal use or service. This warranty does not apply to defect or damage occurring as a result of disaster, accident, abuse, misuse, lightning, power surges, or failure to follow instructions in any enclosed manuals. Any damage or defects occurring as a result of any unauthorized service or repairs by unauthorized persons shall be excluded from this warranty.

There are no warranties expressed or implied (including any warranty of merchantability or fitness), which extend these warranty period. **The loss of use of the product, loss of time, inconvenience, commercial loss or consequential damages, including costs of any labor, are not covered.** The manufacturer reserves the right to change the design of the product without assuming any obligation to modify any product previously manufactured.

This warranty gives you specific legal rights. You might also have additional rights that may vary from state to state. Some states do not allow limitations on how long an implied warranty lasts. Some states do not allow the exclusion or limitation of incidental or consequential damages. Therefore, the above limitation(s) or exclusion(s) may not apply to you.

If you have any questions concerning this or any other Star product,  
please contact our **Customer Service Department** at (585) 226-9787.

If a product must be returned for any reason,  
please contact our Customer Service Department to obtain a  
Returned Material Authorization number (RMA #) before you ship the product to Star.  
Please write the RMA # clearly on the package near the mailing label.



**PROUDLY MADE IN THE USA**  
An ISO 9001:2008 Certified Company

**Please Note:** These instructions are provided as a general guideline only. *Some vehicles may require special mounting, wiring, and/or weather-sealing. This is the sole responsibility of the installer.* Star Headlight & Lantern Co., Inc. assumes no responsibility for the integrity of the installation for this or any of its products.

 **Star Headlight & Lantern Co., Inc.**  
455 Rochester Street Avon, NY 14414 Phone: 585-226-9787 FAX: 888-478-2797  
**STAR** **STAR** **STAR** **BRADFORD** [www.starheadlight.com](http://www.starheadlight.com)  
SINCE 1889 WARNING SYSTEMS VEHICLE PRODUCTS Vehicle Solutions